



SERVICE MANUAL

UHF FM TRANSCEIVER

IC-4GA

IC-4GAT

IC-4GE

INTRODUCTION

This service manual contains information relative to the theoretical, physical, mechanical and electrical characteristics of the **IC-4GA/GAT/GE** UHF FM TRANSCEIVER. For further information, please contact an authorized Icom Dealer or Icom Service Center.

VERSIONS

The following version numbers are often used in this manual.

MODEL NAME	VERSION	VERSION NUMBER
IC-4GA	Australia	07
IC-4GAT	USA	05
IC-4GAT	Southeast Asia	09
IC-4GE	Europe	04

ORDERING PARTS

For the fastest service, please supply all of the following information when ordering parts from your dealer or Icom Service Center:

1. 10-digit ordering number (for mechanical parts only)
2. Part number and name
3. Equipment model and unit name
4. Quantity required

Example: 8810004870, PH B0 M2×2.5, screw, IC-4GA, LOGIC-B UNIT, 10 pcs.

Example: μ PD75308GF-035-3B9, IC, IC-4GE, LOGIC-A UNIT, 3 pcs.

REPAIR NOTE

1. **DO NOT** open transceiver covers until the transceiver is disconnected from a power source.
2. **DO NOT** connect the transceiver to an external power source of more than 16 V.
3. **DO NOT** force any of the variable components. Turn them slowly and smoothly.
4. **DO NOT** short any circuits or electronic parts.
5. An insulated tuning tool **MUST BE** used for all adjustments.
6. **DO NOT** keep the power on for a long time when the transceiver is defective.
7. **DO NOT** transmit into a signal generator or sweep generator.
8. **ALWAYS** connect a 30 dB or 40 dB attenuator between the transceiver and a deviation meter or spectrum analyzer when using such test equipment.
9. Read the test equipment instruction manual thoroughly before connecting the equipment to the transceiver.



TABLE OF CONTENTS

SECTION	1 SPECIFICATIONS	1-1
SECTION	2 OUTSIDE AND INSIDE VIEWS	2-1~4
	2-1 FRONT AND SIDE PANELS	2-1
	2-2 TOP PANEL	2-2
	2-3 FUNCTION DISPLAY	2-2
	2-4 MAIN UNIT	2-3
	2-5 RF UNIT	2-4
	2-6 SPEAKER AND DTMF UNITS.....	2-4
SECTION	3 BLOCK DIAGRAM	3-1
SECTION	4 CIRCUIT DESCRIPTION	4-1~7
	4-1 RECEIVER CIRCUITS	4-1
	4-2 TRANSMITTER CIRCUITS	4-2
	4-3 PLL CIRCUITS	4-3
	4-4 POWER SUPPLY CIRCUITS	4-4
	4-5 OTHER CIRCUITS	4-4
	4-6 CPU (IC501) PORT ALLOCATION	4-6
	4-7 MATRICES	4-7
SECTION	5 MECHANICAL PARTS AND DISASSEMBLY	5-1~2
SECTION	6 ADJUSTMENT PROCEDURES	6-1~4
	6-1 PLL ADJUSTMENT	6-1
	6-2 RECEIVER ADJUSTMENT	6-2
	6-3 TRANSMITTER ADJUSTMENT	6-3
SECTION	7 BOARD LAYOUTS	7-1~9
	7-1 INTERCONNECTION	7-1
	7-2 LOGIC-A UNIT	7-2
	7-3 LOGIC-B UNIT	7-3
	7-4 RF UNIT	7-4
	7-5 MAIN UNIT	7-6
	7-6 OTHER UNITS	7-8
SECTION	8 VOLTAGE DIAGRAM	8-1~3
	8-1 LOGIC UNIT	8-1
	8-2 RF UNIT	8-2
	8-3 MAIN UNIT	8-3
SECTION	9 PARTS LIST	9-1~5

The SCHEMATIC DIAGRAM is attached at the end of this service manual.

SECTION 1 SPECIFICATIONS

■ GENERAL

Frequency coverage	:	430.000~440.000 MHz (All models except USA) 440.000~450.000 MHz (USA only)	
Mode	:	F3 (FM)	
Memory channels	:	20 and 1 call channel 20 (IC-4GE only)	
Antenna impedance	:	50 Ω , unbalanced	
Power supply requirement	:	5.5~16.0 V DC, negative ground	
Current drain	:	Receive	Max. audio output 250 mA Power saver on (typical) 12 mA
		Transmit	HIGH 2.3 A; LOW 1.2 A
Usable temperature range	:	-10 °C~+60 °C (+14 °F~+140 °F)	
Frequency stability	:	± 10 ppm (-10 °C~+60 °C/+14 °F~+140 °F)	

Dimensions

	W	H	D
With BP-3	65 (2.6)	130 (5.1)	35 (1.4)
With BP-4	65 (2.6)	140 (5.5)	35 (1.4)
With BP-70	65 (2.6)	151 (5.9)	35 (1.4)

Unit: mm (in)

Weight	:	With BP-3	430 g (15 oz)
		With BP-4	450 g (1 lb)
		With BP-70	500 g (1.1 lb)

■ TRANSMITTER

Output power	:	HIGH 6 W (with BP-70); 3.5 W (with BP-3) LOW 1 W
Modulation system	:	Variable reactance frequency modulation
Maximum frequency deviation	:	± 5 kHz
Spurious emissions	:	Less than -60 dB
Microphone impedance	:	2 k Ω

■ RECEIVER

Receive system	:	Double-conversion superheterodyne
Intermediate frequencies	:	1st 23.15 MHz 2nd 455 kHz
Sensitivity	:	Less than 0.25 μ V for 12 dB SINAD
Squelch threshold sensitivity	:	Less than 0.1 μ V
Spurious response rejection	:	Less than -60 dB
Audio output power	:	More than 400 mW at 10% distortion with an 8 Ω load
Audio output impedance	:	8 Ω

All stated specifications are subject to change without notice or obligation.

SECTION 2 OUTSIDE AND INSIDE VIEWS

2 - 1 FRONT AND SIDE PANELS

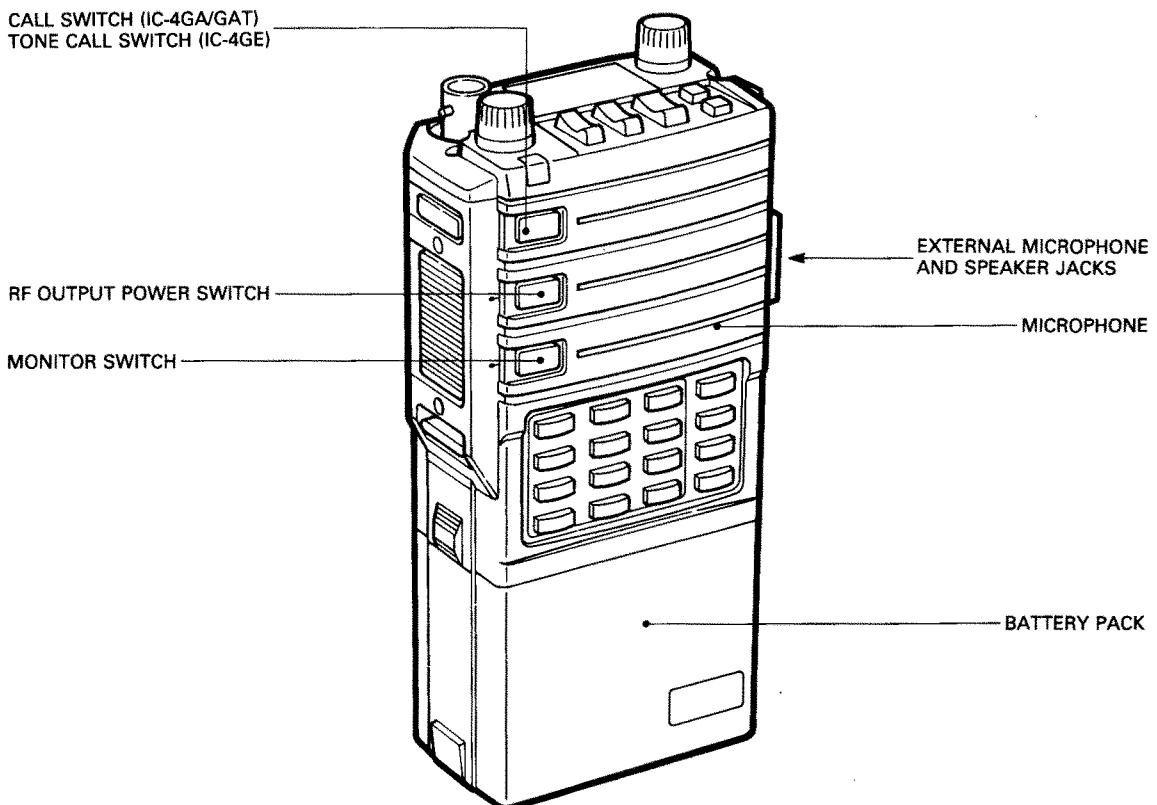
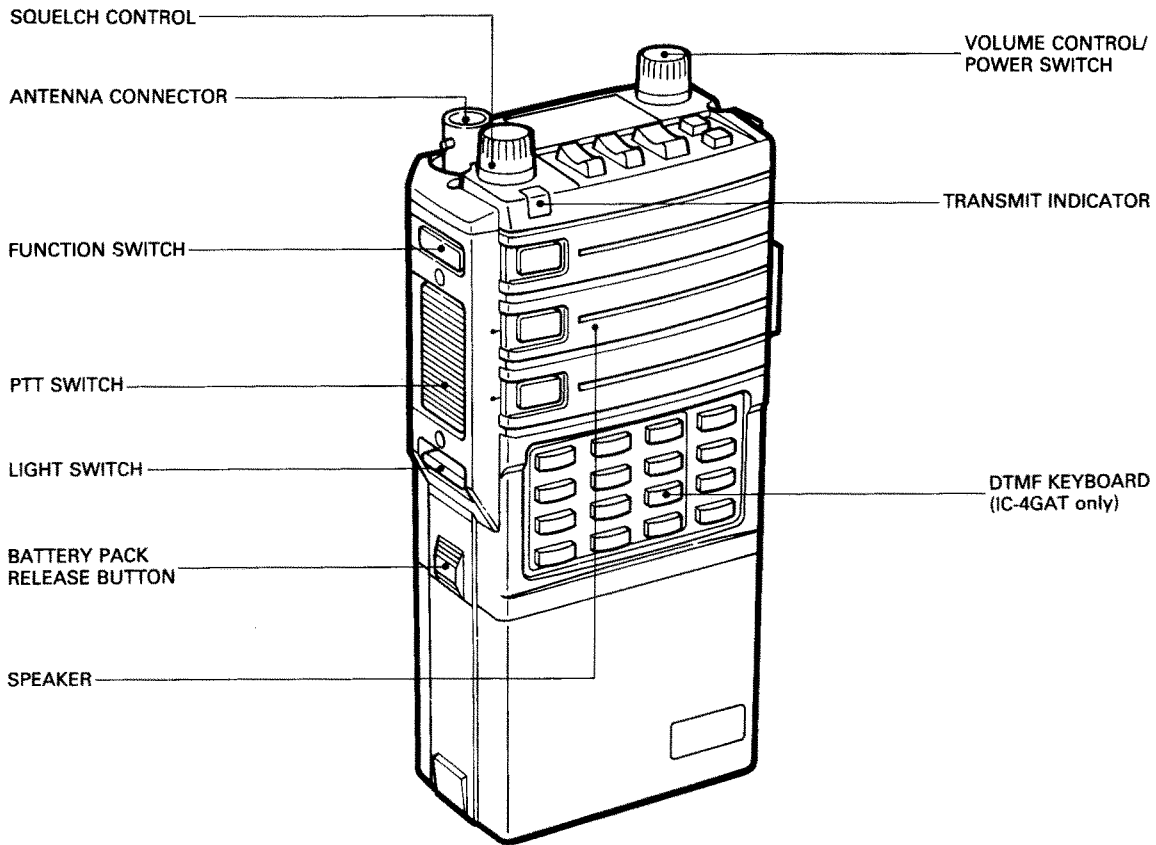

2 - 2 TOP PANEL

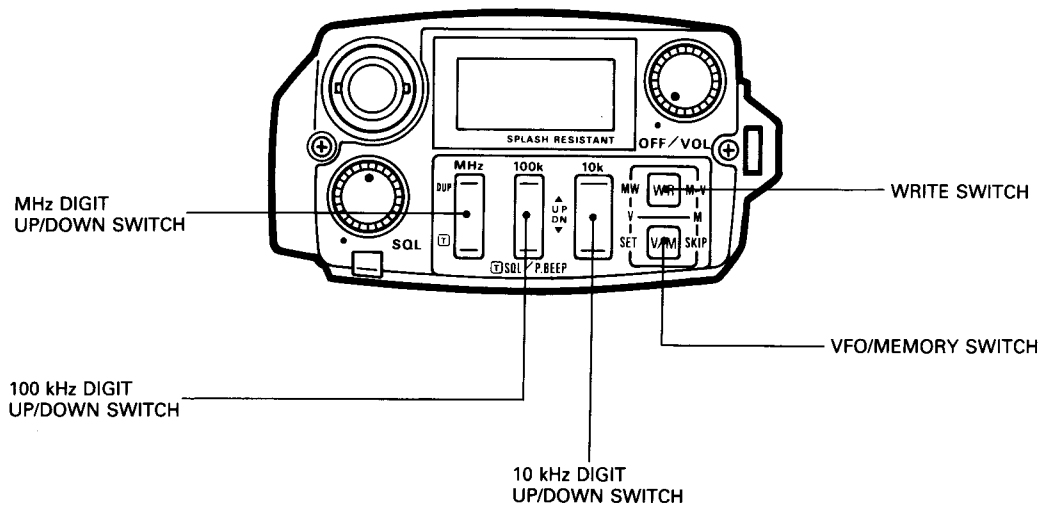

2 - 3 FUNCTION DISPLAY

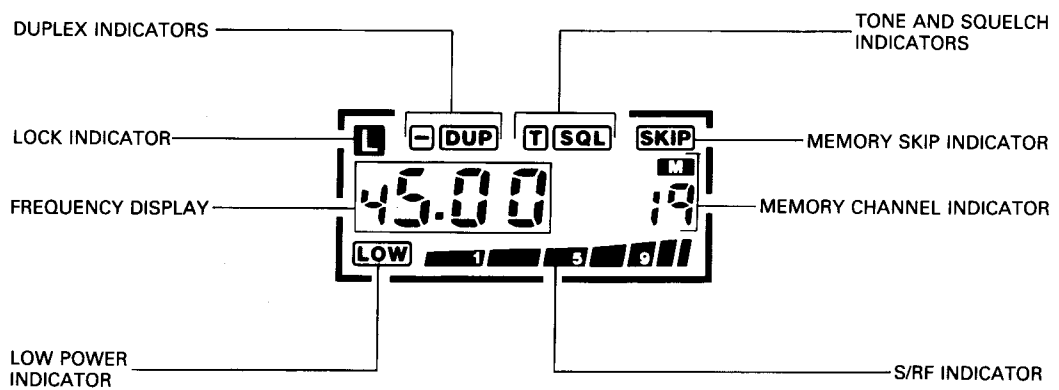

2 - 4 MAIN UNIT

IC-4GA, IC-4GAT

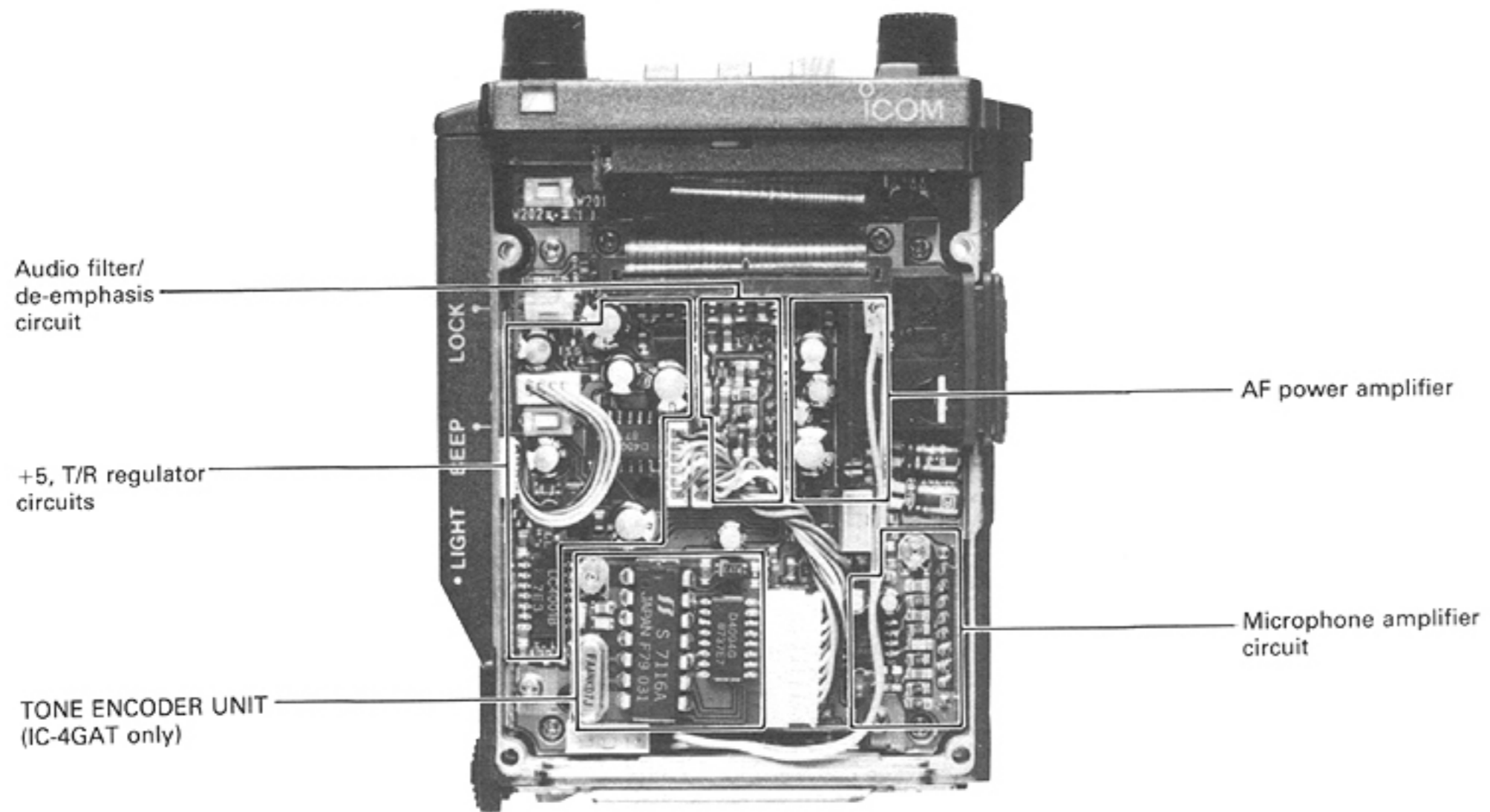

IC-4GE

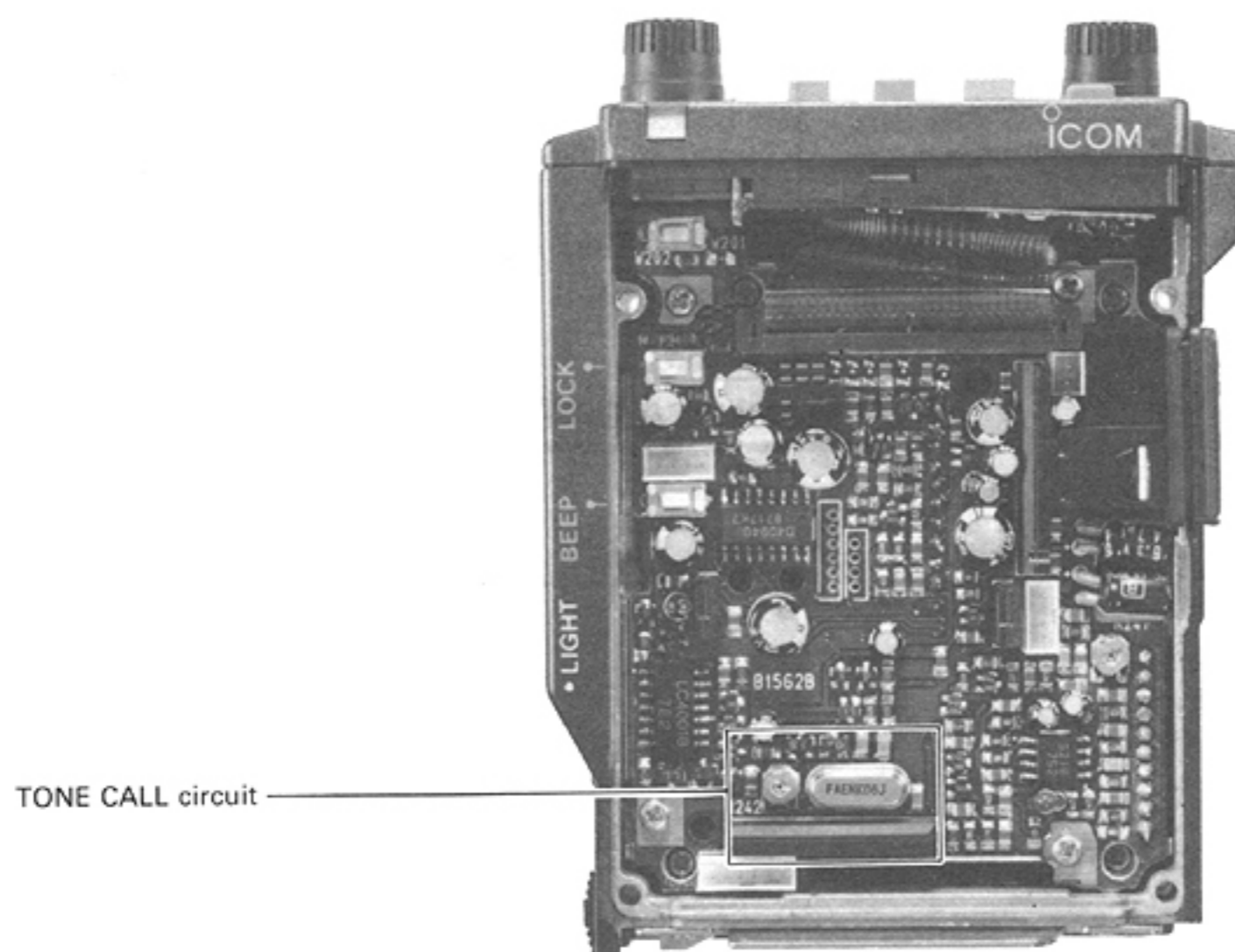

2 - 5 RF UNIT

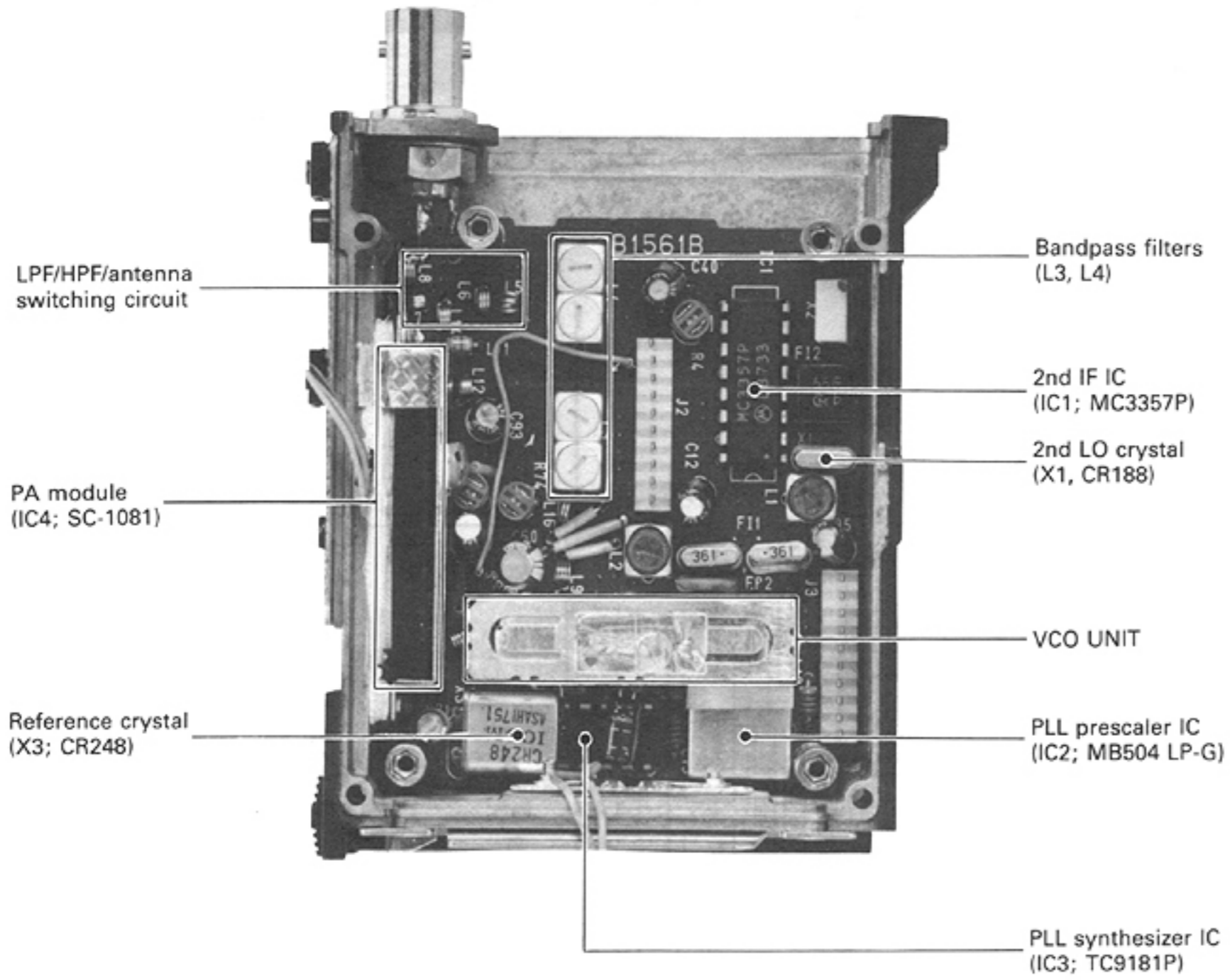

2 - 6 SPEAKER AND DTMF UNITS

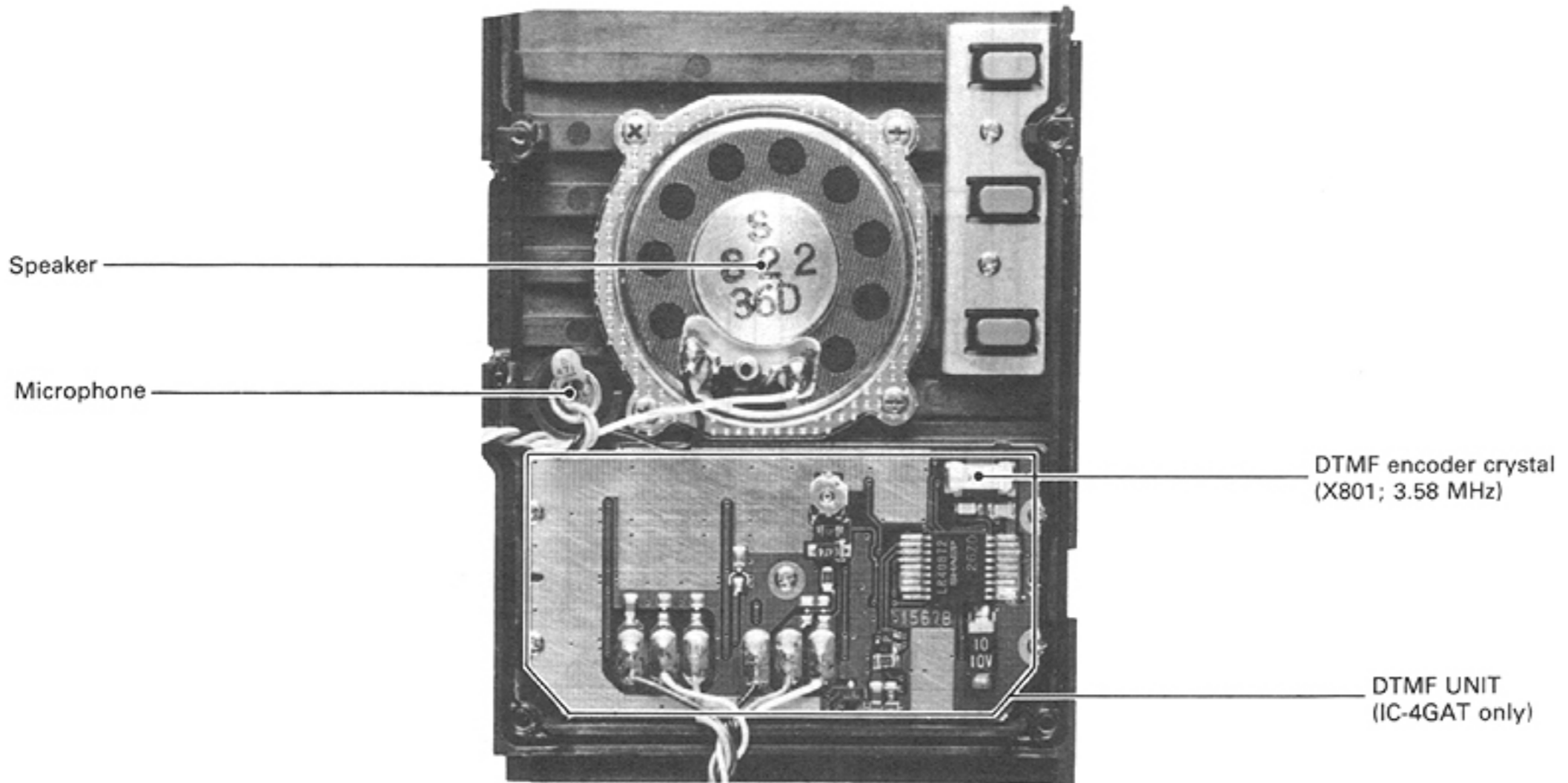

SECTION 3 BLOCK DIAGRAM

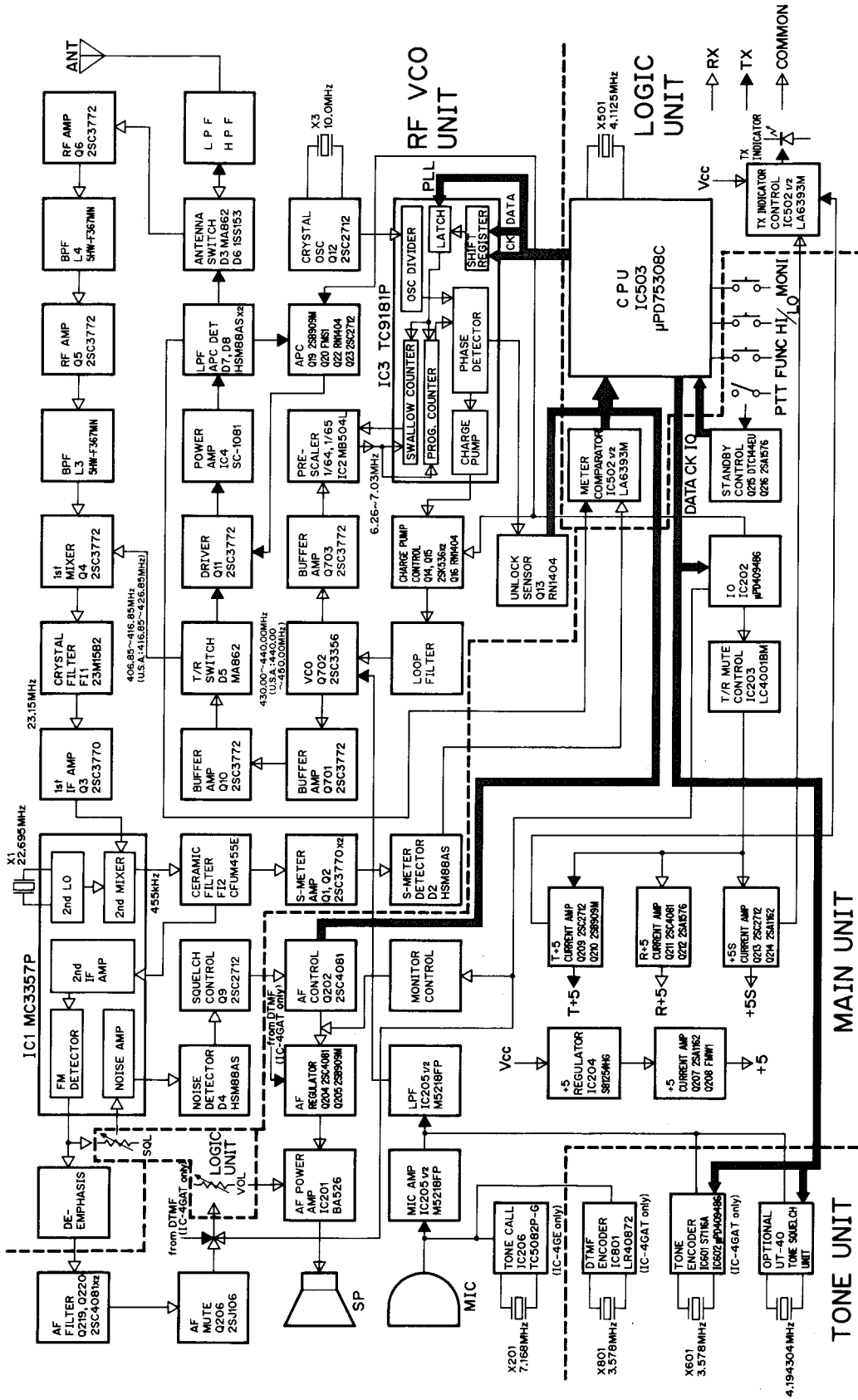

SECTION 4 CIRCUIT DESCRIPTION

4 - 1 RECEIVER CIRCUITS

4 - 1 - 1 ANTENNA SWITCHING CIRCUIT (RF UNIT)

RF signals enter the antenna connector and pass through a series of Chebyshev low-pass filters (L7, L8, C33~C35). Passing through a high-pass filter (L14, C31, C32), the signals are then applied to the antenna switching circuit, which employs a two-stage diode switching system (L5, L6, C28, C29, D3).

4 - 1 - 2 RF CIRCUIT (RF UNIT)

The signals from the antenna switching circuit are amplified at Q6, applied to a bandpass filter (L4), amplified again at Q5, and then applied to another bandpass filter (L3). Out-of-band signals are suppressed at L3 and L4.

4 - 1 - 3 1st MIXER CIRCUIT (RF UNIT)

The signals are applied to the base of the 1st mixer (Q4). A frequency oscillated in the PLL circuit passes through the LO switching circuit (D5), and is applied to the base of Q4. The received signals are mixed with the PLL output to produce the 1st IF of 23.15 MHz.

4 - 1 - 4 1st IF FILTER AND AMPLIFIER (RF UNIT)

The 1st IF signal is applied to a set of two monolithic filters (F1) which determines the bandwidth (15 kHz/−3 dB) and suppresses unwanted heterodyned signals. The 1st IF signal is amplified at Q3, and then applied to IC1 (pin 16).

4 - 1 - 5 2nd IF AND DEMODULATOR CIRCUITS (RF UNIT)

IC1 contains the 2nd local oscillator, the 2nd mixer, a limiter amplifier, and the quadrature detector.

Using X1, IC1 oscillates a 2nd Lo frequency of 22.695 MHz. The 1st IF signal, applied to pin 16, is mixed with the 2nd Lo signal to be converted to a 2nd IF signal. The 2nd IF of 455 kHz is output from pin 3. Applied to IC1 (pin 5), the 2nd IF is amplified at the IC's internal limiter amplifier. The amplified signal is applied to the quadrature detector at pin 8. An AF signal is output from pin 9.

After passing through the ceramic filter (F12), a portion of the 2nd IF signal is applied to Q1 and Q2. Q1 and Q2 amplify the signal, which is used by the S/R indicator to show relative signal strength.

4 - 1 - 6 AF CIRCUIT (MAIN UNIT)

The AF signal is applied to the de-emphasis circuit (C40, R32), and then to the AF amplifier (Q219, Q220). The de-emphasis circuit is an integrated circuit with frequency characteristics of −6 dB/octave (300 Hz~3 kHz). Passing through the volume control (R502), the signals are amplified by IC201, and sent to the speaker (SP201).

4 - 1 - 7 SQUELCH CIRCUIT (RF AND MAIN UNITS)

A portion of the AF signal from IC1 (pin 9) is applied to pin 10 (the active filter). The squelch control (R501) adjusts the input level at pin 10. The active filter in IC1 amplifies noise components of frequencies of 20 kHz and above, and outputs the resulting signals from pin 11. The signals pass through D4 for noise detection. If the detected noise voltage is high, Q9 is turned on; Q202 in the MAIN UNIT is turned off, cutting off the output voltage of the voltage regulator (Q204, Q205) in the AF power amplifier. In this way, IC201 is deactivated when the squelch is closed. When transmitting, a decrease in Q202 voltage cuts off the output of the voltage regulator — turning off IC201.

IF CIRCUIT

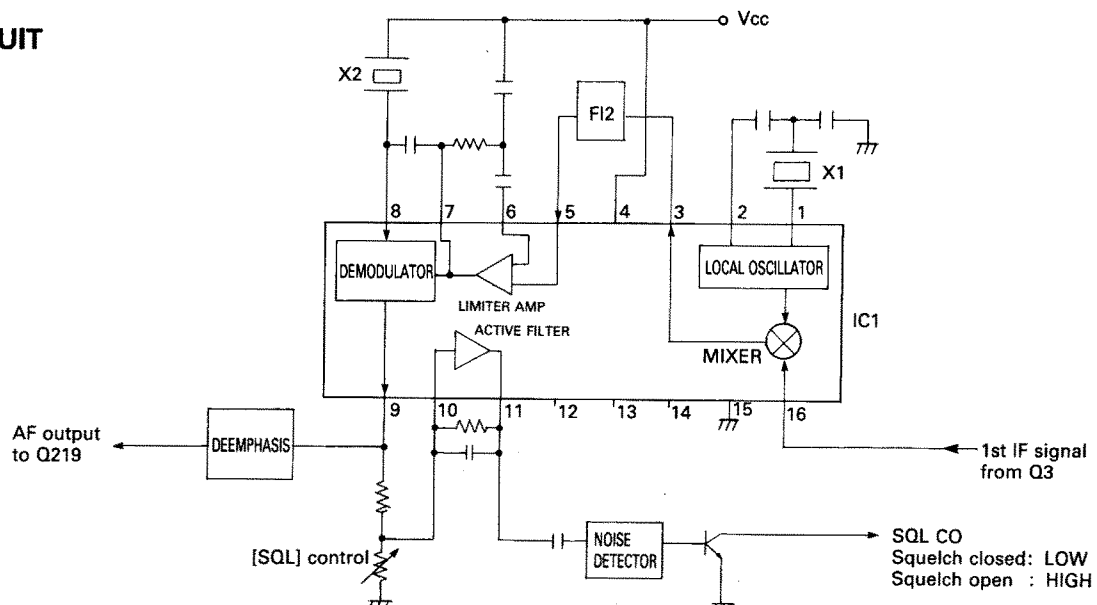

4 - 2 TRANSMITTER CIRCUITS

4 - 2 - 1 MICROPHONE AMPLIFIER (MAIN UNIT)

AF signals from the built-in condenser microphone (MC201) or from the external microphone jack (J202) are amplified at a limiter amplifier (IC205), and are pre-emphasized to 6 dB/octave (300 Hz~3 kHz). Pin 1 outputs a square wave which contains many high harmonic components. The signals pass through the splatter filter in IC205 where signals of 3 kHz and above are attenuated. The signals from pin 7 are applied to the VCO UNIT for frequency modulation (FM).

4 - 2 - 2 DRIVE AMPLIFIER (RF UNIT)

The VCO output is buffer-amplified at Q10. Passing through D5, the signals are then amplified at the drive amplifier (Q11).

4 - 2 - 3 RF POWER AMPLIFIER (RF UNIT)

When the battery voltage is 13.2 V, Q11 output is amplified at IC4 to 6 W (HIGH) or 1 W (LOW). The RF signals amplified at IC4 pass through the antenna switching diode (D6) and the low pass filter where harmonics are rejected. The signal is then applied to the antenna connector (J1).

4 - 2 - 4 APC CIRCUIT (Automatic Power Control) (RF UNIT)

A portion of IC4 output passes through the APC detector circuit (D7, D8, L12, etc.) where its RF output level is detected.

The detected output, compared at the differential amplifier (Q20) to the reference voltage output of the power set circuit, is applied to the base of Q23.

When the antenna is matched at 50 Ω , the detected output is at a minimum. When mismatched, the detected output increases. The current at the collectors of Q19 and Q23, as well as the gain of the driver (Q11), decreases until the detected output equals the reference voltage. In this way, the power module (IC4) is protected from damage.

Q22 acts as a switch for the reference voltage used in the APC circuit. In this way, HIGH/LOW transmit output power switching is accomplished.

APC CIRCUIT

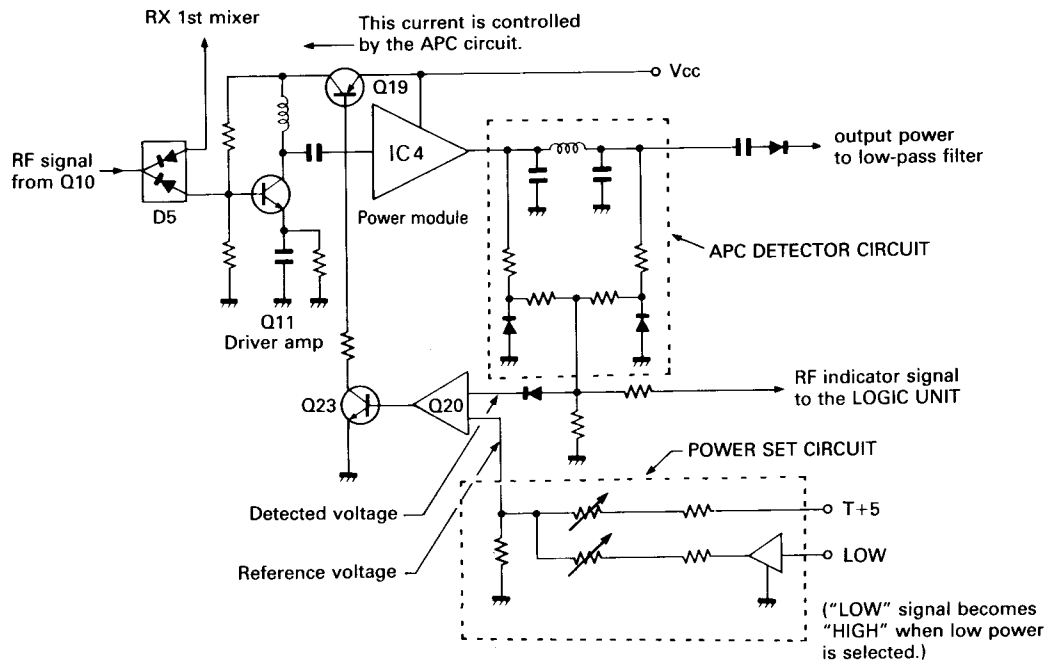

4 - 3 PLL CIRCUITS

4 - 3 - 1 GENERAL

The PLL circuit uses two ICs — a prescaler IC and a programmable divider/phase detector IC — to generate the desired frequency. IC2 sets the dividing ratio at 1/64 or 1/65 depending on the swallow counter PSC signal output from IC3 pin 7. IC3 divides the signal and compares the phase of the divided signal to that of the reference oscillator frequency. The phase-detected signals are output from IC3 pin 17.

4 - 3 - 2 REFERENCE OSCILLATOR CIRCUIT (RF UNIT)

Q12 oscillates a 10 MHz signal using crystal unit X3. IC3 divides this signal with N-data from the CPU, creating tuning steps of 5, 10, 12.5, 15, 20 or 25 kHz.

4 - 3 - 3 CHARGE PUMP AND LOOP FILTER CIRCUITS (RF UNIT)

Phase-detected signals from IC3 pin 17 are converted to DC voltage by the lag-lead loop filter (R63~R65, C84, C109, C114).

When the power save function is on, the charge pump control circuit (Q14~Q16, D9) cuts off between IC3 and the charge pump.

4 - 3 - 4 VCO AND FREQUENCY MODULATION CIRCUIT (RF UNIT)

D701 changes the inductive reactance of the oscillator (Q702), shifting the receive and transmit frequencies, creating a frequency modulated signal.

4 - 3 - 5 UNLOCK SENSOR CIRCUIT

When the PLL is unlocked, pin 13 of IC3 is "HIGH." The collector of the unlock sensor (Q13) outputs a "LOW" signal to the CPU, IC503 (pin 60).

PLL CIRCUIT BLOCK DIAGRAM

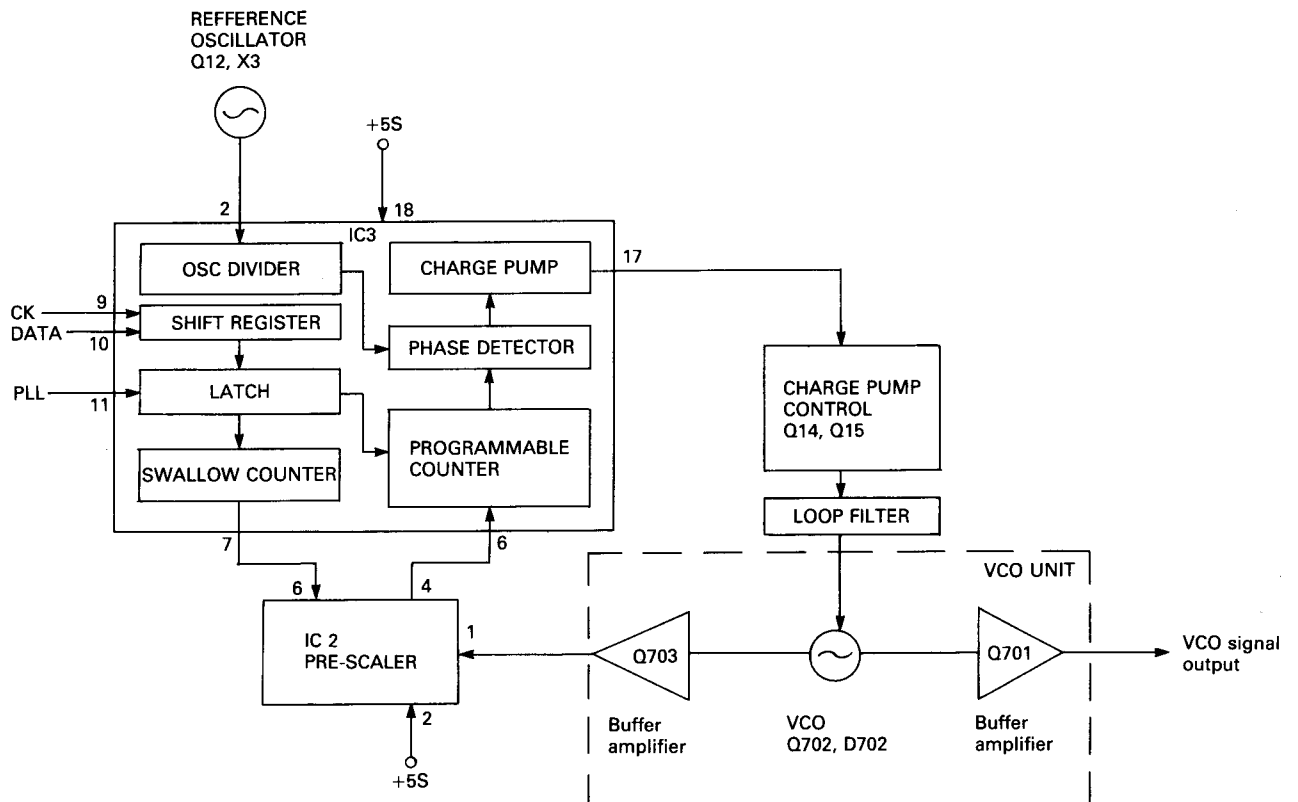

4 - 4 POWER SUPPLY CIRCUITS

4 - 4 - 1 VOLTAGE LINES

LINE	DESCRIPTION
Vc	Battery pack output that passes through the power switch (R502). Vcc is applied to the power module (IC4), the AF power amp regulator, and the following 5 V lines.
+5	Common 5 V current-amplified at Q207 and Q208 using IC204 output as a reference voltage. The heat factor voltage at Q207 (V_{BE}) equals that of the junction voltage at Q208. The output is stable even with regard to temperature changes.
+5S	5 V controlled by the power save function. Current-amplified at Q213 and Q214.
R+5	5 V controlled by the power save function. Current-amplified at Q211 and Q212. Used by the receiver circuits.
T+5	5 V current-amplified at Q209 and Q210. Used by the transmitter circuits.

4 - 4 - 2 VOLTAGE REGULATOR CIRCUIT (MAIN UNIT)

When the battery voltage is 5.5~16 V, the voltage regulator (IC204) outputs a reference voltage of 5 V. The noise components are removed by the noise filter (C220, R213). This output is applied to the current amplifier (Q207, Q208).

4 - 4 - 3 CPU POWER SUPPLY CIRCUIT (LOGIC UNIT)

When the power is turned off, voltage from the lithium battery (BT501) is applied via D502 to the CPU (IC503) at pin 52.

4 - 5 OTHER CIRCUITS

4 - 5 - 1 S/R/F INDICATOR CIRCUIT (LOGIC UNIT)

The voltages detected at Q1, Q2, and D2 or the APC detector (D7, D8) are applied to pin 2 of IC502. When the voltage level is detected, IC503 (pin 52) outputs a "HIGH" signal. Because the signal passes through an integrator circuit (C507, R517), the voltage at pin 3 increases with time. When the voltage at pin 3 is greater than that at pin 2, pin 1 outputs a "HIGH" signal to IC503 (pin 51). When IC503 (pin 52) becomes "HIGH," the S/R/F level, calculated from the time delay, is displayed on the function display.

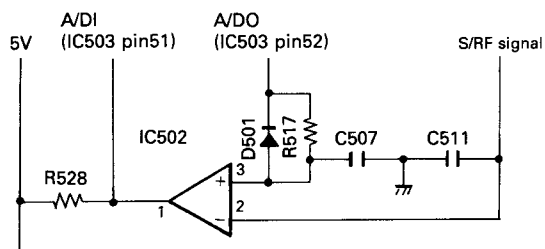

4 - 5 - 2 LAMP CIRCUIT (LOGIC UNIT)

When the LIGHT SWITCH is pushed, the IC503 (pin 53) LAMP signal becomes "HIGH." The current of this signal is amplified at Q501 to light the two chip-type LED (DS502, DS503) for five seconds.

4 - 5 - 3 LOW VOLTAGE DETECTOR CIRCUIT (LOGIC UNIT)

+5S is divided over R523 and R524. 1.16 V are applied to IC502 (pin 5). The Vcc voltage, divided over R525 and R526, is applied to pin 6. When the Vcc voltage exceeds 5.7 V, the voltage at pin 6 becomes greater than that at pin 5. Output pin 1 becomes "LOW." When the Vcc voltage is less than 5.7 V, the voltage at pin 5 exceeds that at pin 6. Pin 1 outputs "HIGH." The transmit indicator (DS504) does not light even when transmitting.

4 - 5 - 4 BEEP CIRCUIT (MAIN UNIT)

When some switches are pushed, the CPU sends BEEP data to IC202. Beep tones are output from IC202 (pin 5) in square waves of about 1 kHz and 500 Hz.

4 - 5 - 5 POWER SAVER CIRCUIT (MAIN UNIT)

When the squelch is closed, IC503 (pin 41) BUSY signal is "LOW." If controls and switches are not used for 30 seconds, the power save function is automatically activated. After 30 seconds, IC503 sends power save data to IC202.

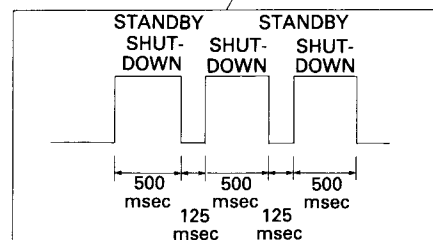
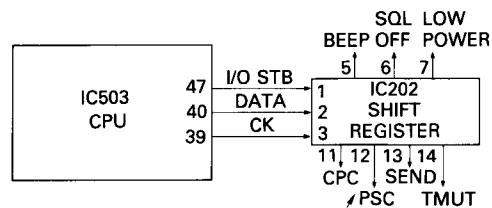

Using this data, IC202 (pin 12) alternately outputs "HIGH" (shut-down) for 500 msec. and "LOW" (standby) for 125 msec. This output, applied to IC203D (pins 5 and 6) and IC023C (pin 9), controls the bases of Q211 and Q213, thus controlling +5S and R+5.

If a signal is received, the BUSY signal becomes "HIGH," shutting off the power save function. If a signal is not received, "HIGH" and "LOW" signals continue to alternate.

4 - 5 - 6 SUBAUDIBLE TONE ENCODER (IC-4GAT)

When the tone encoder is turned on, the X601 reference frequency (3.58 MHz) is divided by IC601's dividing ratio based on 6-bit data from IC503. A tone (67.5 Hz~250.3 Hz) is output from pin 1. The tone passes through R601 for deviation adjustment and is supplied to the MAIN UNIT.

4 - 5 - 7 TONE CALL (IC-4GE)

Pushing the tone call switch (S206) turns on Q218. A voltage is applied to IC206. IC206 divides 7.168 MHz by 4,096; and outputs a 1750 Hz tone through pin 4. R242 provides deviation adjustment.

4 - 5 - 8 DTMF ENCODER (IC-4GAT)

IC801 generates DTMF tone signals. When transmitting, T+5V are applied to IC801 (pins 1 and 2). If, at this time, data are entered with the DTMF KEYBOARD, the frequency (3.58 MHz) oscillated by X801 is divided by the appropriate dividing ratio.

Pin 17 outputs audio frequencies corresponding to ROW and COL input. R801 provides deviation adjustment. When a key is pushed, a "HIGH" signal is output to pin 11. Q801 is turned on for about one second to maintain transmission without pushing the PTT SWITCH (S205).

4 - 5 - 9 T+5/R+5 SWITCHING CIRCUIT (MAIN UNIT)

When the PTT SWITCH (S205) is pushed, Q216 is turned on. The collector of Q215 outputs a "LOW" signal to the CPU (IC503, pin 44). Using the "LOW" signal, the CPU sends TRANSMIT data to IC202. IC202 (pin 13) outputs a "HIGH" signal to IC203C (pin 8) and IC203A (pins 12 and 13), controlling IC203C (pin 10) — shutting off R+5.

IC203A (pin 11) outputs a "LOW" signal to IC203B (pin 2), controlling the base of Q209 — turning on T+5.



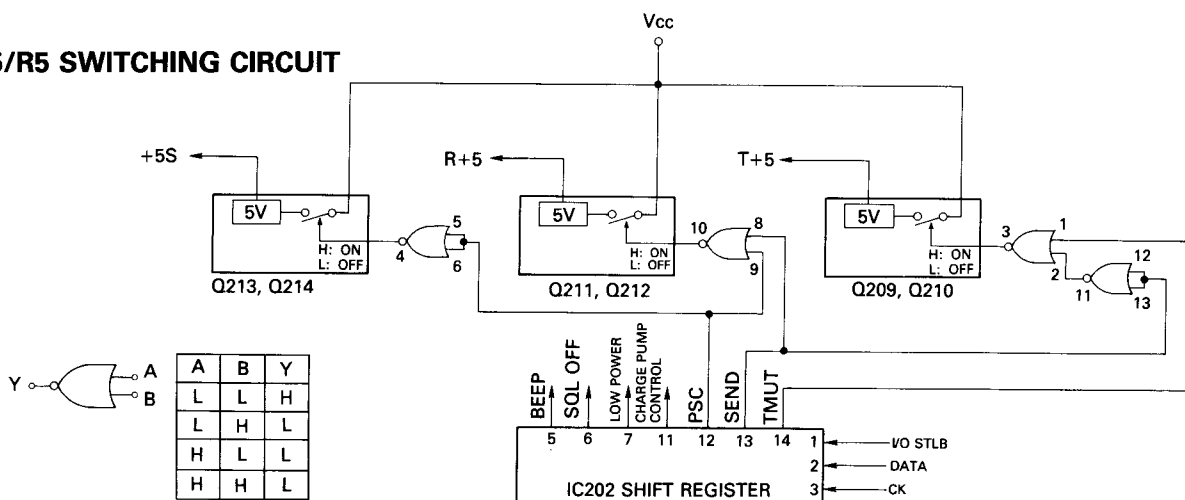

Releasing the PTT SWITCH turns off Q216. The collector of Q215 outputs a "HIGH" signal which causes the CPU to send RECEIVE data to IC202. IC202 (pin 13) outputs a "LOW" signal to IC203C (pin 8) and IC203A (pins 12 and 13), controlling IC203C (pin 10) — turning on R+5.

IC203A (pin 11) outputs a "HIGH" signal to IC203B (pin 2), controlling the base of Q209 — turning off T+5.

T5/R5 SWITCHING CIRCUIT



4 - 6 CPU (IC501) PORT ALLOCATION

PIN	PORT	STANDBY		OPERATION		NAME	DESCRIPTION
		I/O	H/L	I/O	H/L		
1~28	S13~S31	COM					
29	P40	O	L	O	L	KS0	Output for the SW matrix.
30	P41	O	L	O	L	KS1	Output for the SW matrix.
31	P42	O	L	O	L	KS2	Output for the SW matrix.
32	P43	O	L	O	L	KS10	Output for the SW matrix.
33	—	—	—	—	—	Vss	Ground
34	P50	O	L	I	L	KR0	Input for the matrix return.
35	P51	O	L	I	L	KR1	Input for the matrix return.
36	P52	O	L	I	L	KR2	Input for the matrix return.
37	P53	O	L	I	L	KR3	Input for the matrix return.
38	P00	I	L	I		INT4	Standby detector input. Goes to standby at the end of a pulse.
39	P01	I	L	O		CK	Serial data output clock: a) PLL N b) CTCSS TONE c) I/O EXPANSION
40	P02	I	L	O	H	DATA	Serial data output synchronized with CK.
41	P03	I	L	I	H	BUSY	BUSY input used when a signal is received.
42	P10	I	L	I	L	LAMP1	Input used for lamp output HI/LOW control.
43	P11	I	L	I	L	MONI	Input used for ON/OFF control of SQL OFF and BEEP output.
44	P12	I	L	I	L	PTT	Tx/Rx switching input.
45	P13	I	L	I	L	FUNC	Switches matrix input to FUNC functions.
46	P20	O	L	O	L	KS11	Output for the initial matrix.
47	P21	O	L	O		I/OSTB	Strobe signal output for I/O expansion serial data.
48	P22	O	L	O		PLSTB	PLL serial data, strobe signal output.
49	P23	O	L	O		CTSTB	CTCSS serial data, strobe signal output.
50	P30	I	L	I	H	DET	Data equalizer signal input from the CTCSS decoder.
51	P31	I	L	I	H	SRFI	S/RF meter comparison input.
52	P32	O	L	O	H	SRFO	S/RF meter comparison output.
53	P33	O	L	O	H	LAMPO	LCD backlight LAMP output.
54	—	—	2 V	—	5 V	VDD	
55~59	—	—	—	—	—	XTAL	
60	P60	I	L	I	L	UNLK	PLL unlock input.
61	P61	O	L	I	L	HI/LOW	Used for HLC output HI/LOW and KEYLOCK ON/OFF switching.
62	P62	O	L	I	L	ENC/DEC	Determines whether or not a CTCSS encoder/decoder (MN6520) is online.
63	P63	O	L	I	L	ENC	Determines whether or not a CTCSS encoder (S7116A) is online.

PIN	PORT	STANDBY		OPERATION		NAME	DESCRIPTION
		I/O	H/L	I/O	H/L		
64	P70	O	L	O	H	DA0	
65	P71	O	L	O	H	DA1	
66	P72	O	L	O	H	DA2	
67	P73	O	L	O	H	DA3	
68	—	I		I	L	RESET	Turns off standby. When resetting, becomes "LOW" for initialization.
69~80	S0~S12	O	H	O	H		LCD driver output

4 - 7 MATRICES

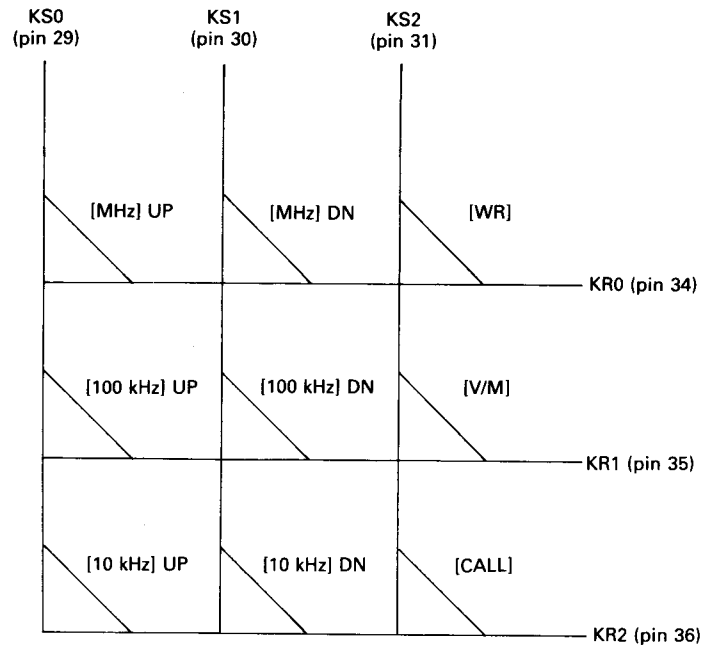

SECTION 5 MECHANICAL PARTS AND DISASSEMBLY

NUMBER	DESCRIPTION	ORDERING NUMBER	QTY	NUMBER	DESCRIPTION	ORDERING NUMBER	QTY
①	No. 0-3 PH B0 1.4 × 2.5 Ni	8810003850	5	⑳	Lens	8930011940	1
②	573 keyboard (IC-4GAT)	8010006870	1	㉑	No. 0-1 PH M2 × 2.5	8810004870	2
③	PH B0 2 × 31.5 ZK	8810004000	4	㉒	Button K-106	8610004210	1
④	Rear panel-1	8010006861	1	㉓	Button K-107	8610004220	2
⑤	No. 0-1 PH B0 2 × 4	8810004800	4	㉔	No. 0-1 PH M2 × 2.5	8810004870	3
⑥	Speaker plate	8930012100	1	㉕	No. 0-3 PH B0 1.4 × 4.5 Ni	8810004980	6
⑦	Casing seal (side)	8930011990	1	㉖	Spacer plate	8930012140	1
⑧	Microphone holder	8930011930	1	㉗	Top panel switch seal	8930011970	1
⑨	Casing seal (center)	8930011870	1	㉘	Top panel (A)* (IC-4GA, IC-4GAT)	8310011520	1
⑩	No. 0-1 PH M2 × 5 ZK	8810000530	2	㉙	Top panel (D)* (IC-4GE)	8310011940	1
⑪	PTT button	8930011910	1	㉚	VR angle plate	8930012120	1
⑫	PTT holder-1	8930011920	1	㉛	LCD contact strip SRCN573	8930012090	2
⑬	PTT switch rubber	8930011950	1	㉜	LCD reflector	8010006980	1
⑭	No. 0-3 PH B0 1.4 × 2.5 Ni	8810003850	2	㉝	LCD LD-B9213J	5030000280	1
⑮	Front switch plate	8930012130	1	㉞	LCD window plate	8310011530	1
⑯	Switch seal (IC-4GA, IC-4GAT)	8310011820	1	㉟	PH M2 × 4	8810000010	4
	Switch seal (B) (IC-4GE)	8310011920	1	㊱	Jack cover flap	8930011980	1
⑰	Speaker seal	8930011580	1	㊲	Antenna connector BNC-R111-E (includes nut)	6510007130	1
⑱	Front panel (B) (IC-4GAT)	8210002900	1	㊳	573 standoff-1	8930012081	4
	Front panel (D) (IC-4GA)	8210002980	1	㊴	No. 0-1 PH M2 × 8 ZK	8810004840	2
	Front panel (E) (IC-4GE)	8210002990	1	㊵	Connection spring	8930005980	1
⑲	Knobs N-126 [OFF/VOL], [SQL]	8610004230	2	㊶	BuH M2 × 6 Ni	8810002580	1
㉑	PH M2 × 6 ZK	8810004860	2	㊷	Release button	8930008610	1
㉒	VR nut (E)	8830000550	2	㊸	Sliding guide	8010006990	1
㉓	Top panel (A)* (IC-4GA, IC-4GAT)	8310011520	1	㊹	FH M2 × 4 Ni	8810002310	4
	Top panel(D)* (IC 4GE)	8310011940	1	㊺	Screw lug M2	8860000010	2
㉔	Top panel seal	8930011970	1	㊻	Contact holder	8930011880	1
				㊼	BuH M2 × 6 Ni	8810002580	1
				㊽	Latch plate (A)-1	8930008601	1

* The top panel is available completely assembled, i.e., with parts ㉑, ㉒, ㉓, ㉔, and ㉕ built-in.
 IC-4GA, IC-4GAT: 8210002870
 IC-4GE : 8210003060

Screw type Screw: M2 × 6, M2 × 3, etc. Self-tapping screw: B0 2 × 4, B0 2 × 31.5, etc. Precision-type screw: No. 0-1
Head style of screws PH: Pan head BuH: Button head FH: Flat head

• CASE AND FRONT PANEL

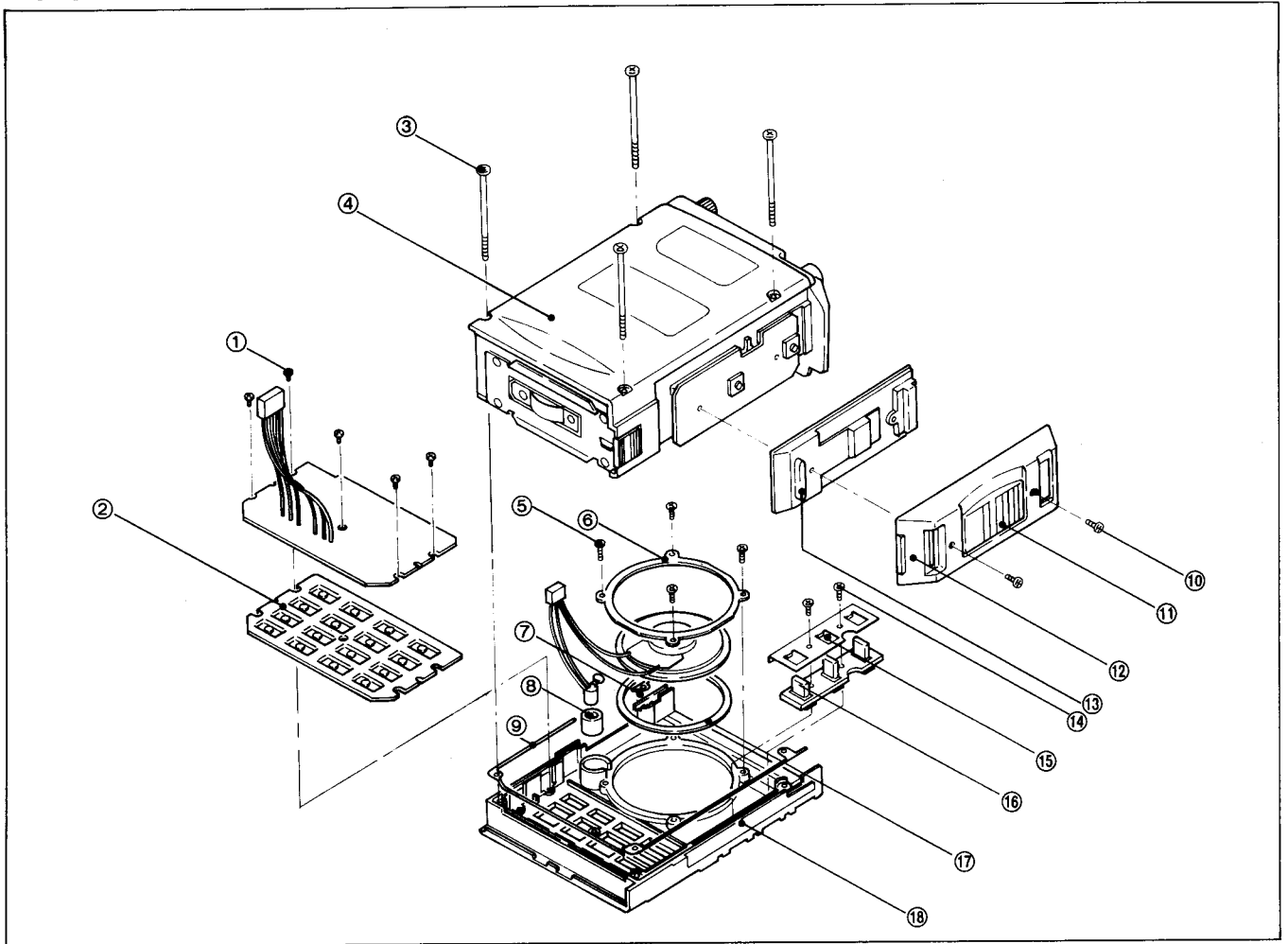

• TOP PANEL

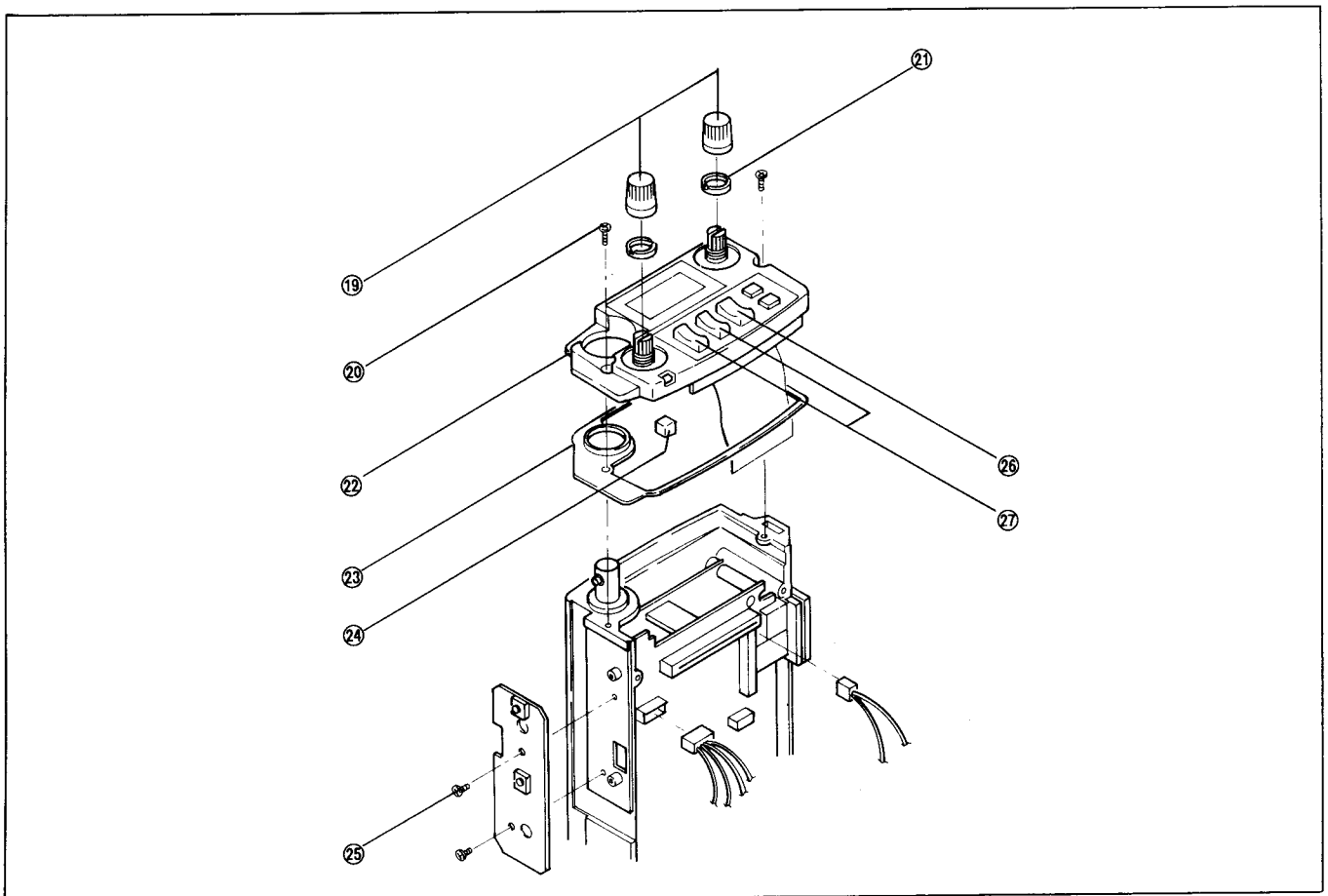

● LOGIC-A AND LOGIC-B UNITS

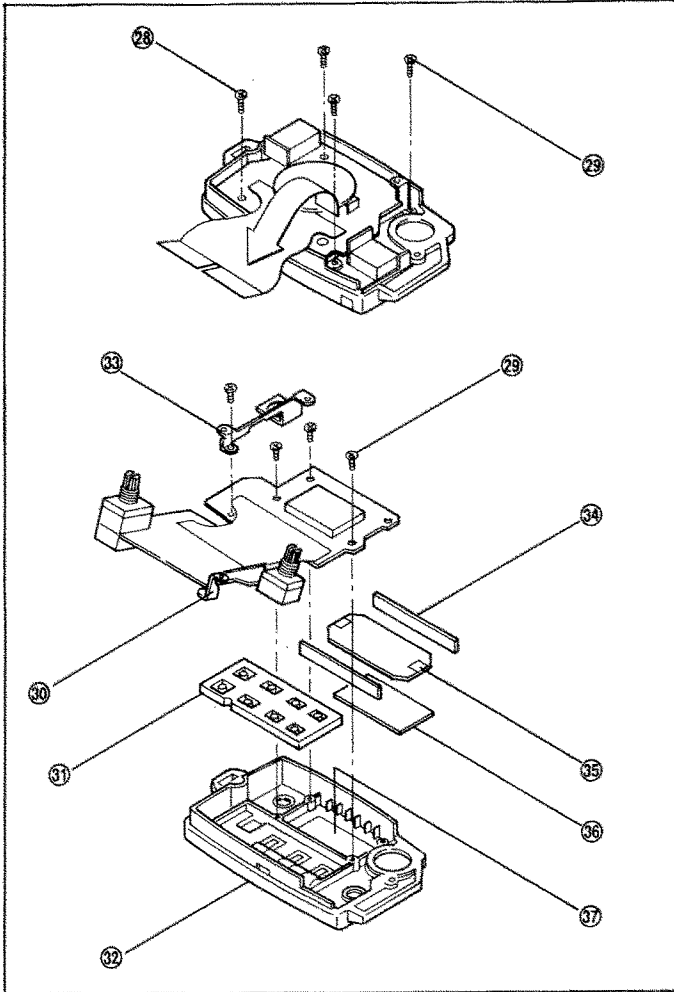

● MAIN UNIT

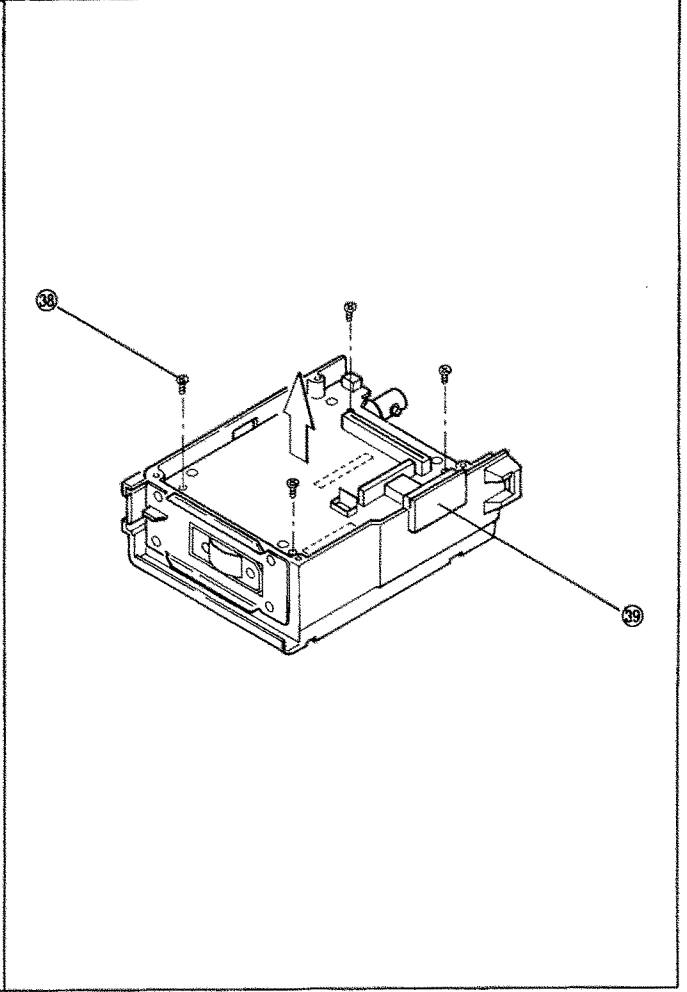

● RF UNIT

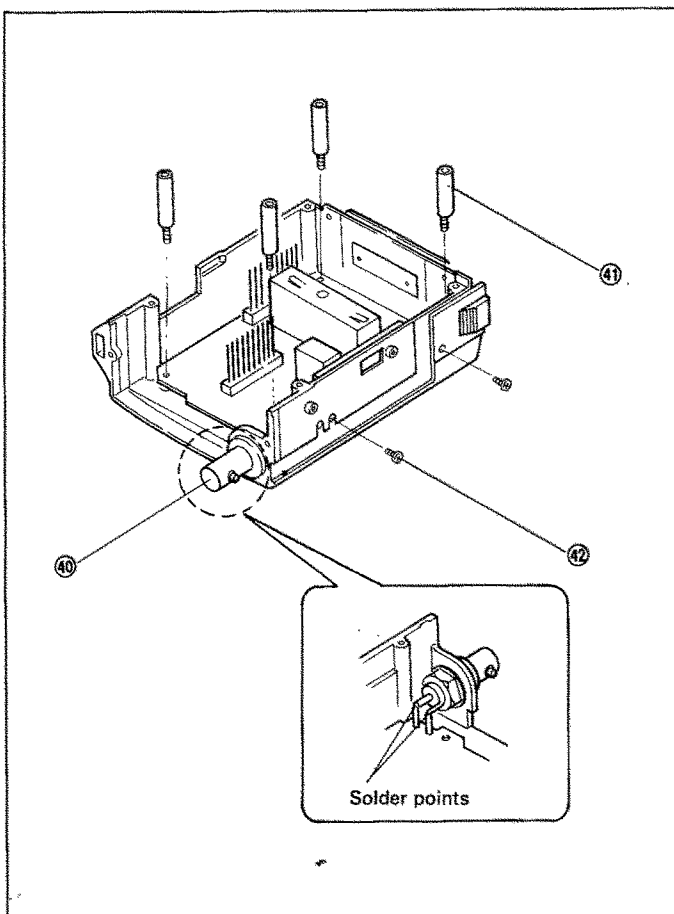

● CONTACT HOLDER

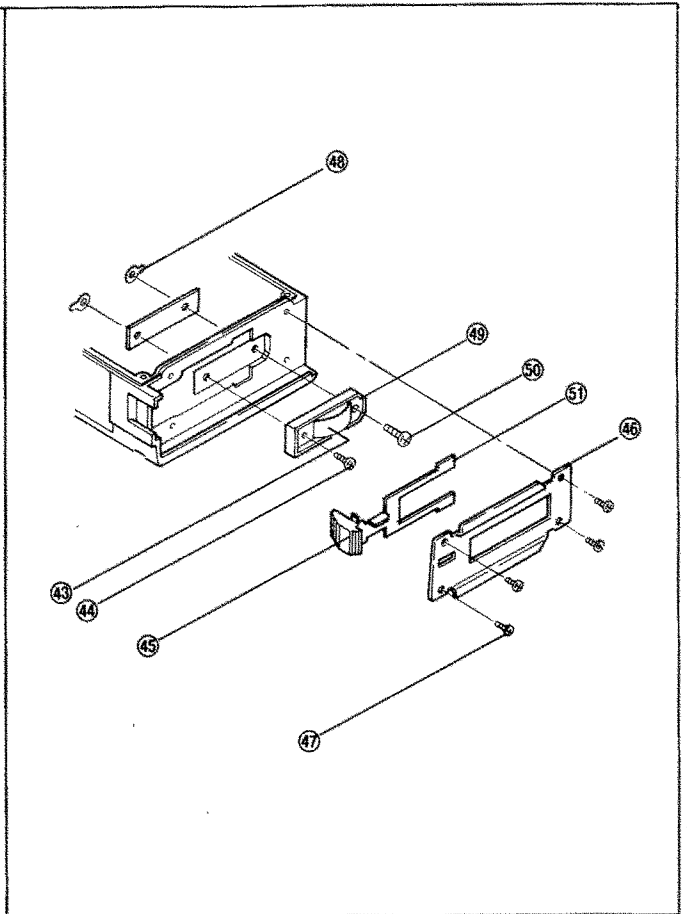

■ SEPARATING THE RF UNIT FROM THE MAIN UNIT

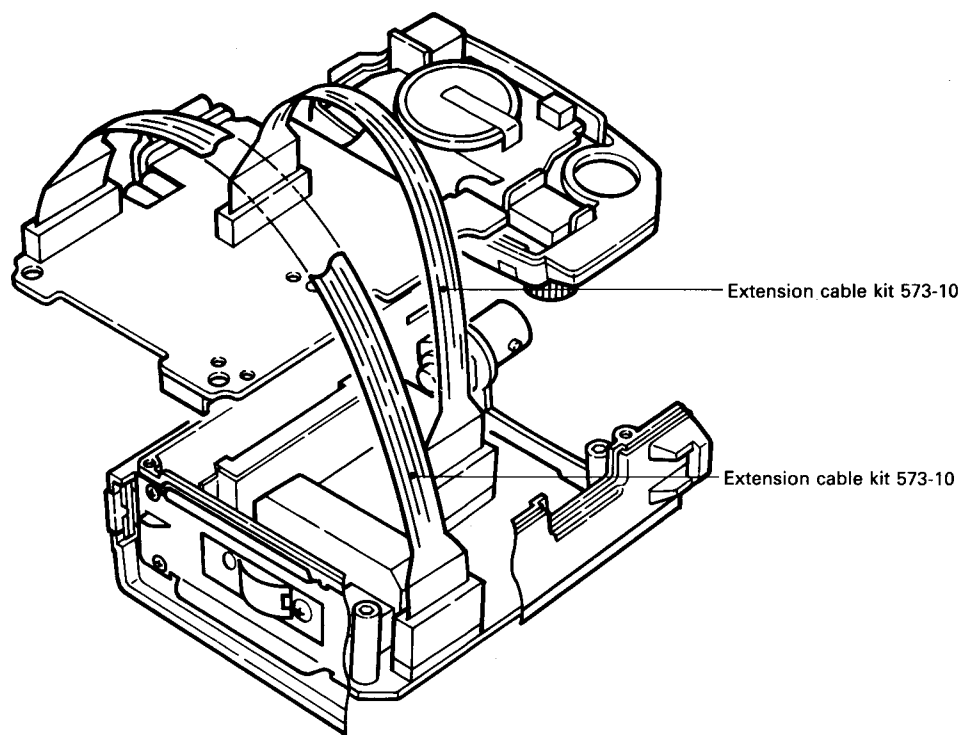

Order the extension cable kits from an authorized Icom Dealer.

SECTION 6 ADJUSTMENT PROCEDURES

6 - 1 PLL ADJUSTMENT

TEST INSTRUMENTS REQUIRED		MEASUREMENT CONNECTION LOCATION				
(1) AC POWER SUPPLY • Output voltage : 13.2 V DC • Current capacity : 3 A or more (2) FREQUENCY COUNTER • Frequency range : 0.1~500 MHz • Frequency accuracy : ± 1 ppm or better • Sensitivity : 100 mV or better (3) DC VOLTMETER • Input impedance : 50 k Ω /DC or better		<p>To separate the RF UNIT from the MAIN UNIT, see the diagram on the reverse of p. 5-2.</p>				
ADJUSTMENT	ADJUSTMENT CONDITIONS	MEASUREMENT		VALUE	ADJUSTMENT POINT	
		UNIT	LOCATION		UNIT	ADJUST
REFERENCE FREQUENCY	<ul style="list-style-type: none"> • Connect a dummy load. • Frequency: 440.00 MHz 450.00 MHz (USA) • Transmit 	Top panel	Loose couple the frequency counter to the dummy load.	440.00 MHz 450.00 MHz (USA)	RF	C71
LOCK VOLTAGE	<ul style="list-style-type: none"> • Frequency: 430.00 MHz 440.00 MHz (USA) • Receive 	RF	Connect the voltmeter to CP1.	1.5 V	VCO	C714

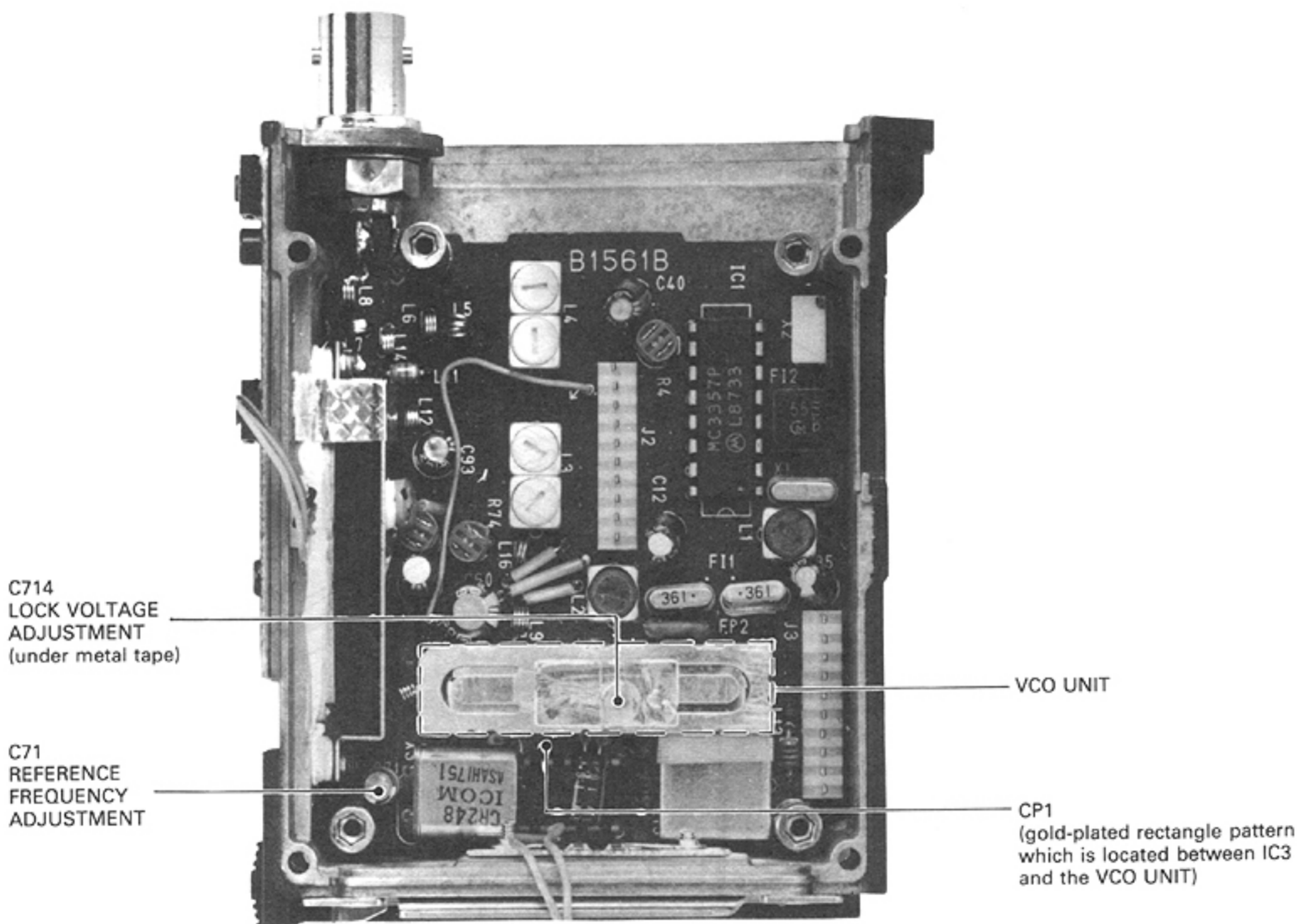

6 - 2 RECEIVER ADJUSTMENT

TEST INSTRUMENTS REQUIRED		MEASUREMENT CONNECTION LOCATION				
(1) AC POWER SUPPLY ● Output voltage : 13.2 V DC ● Current capacity : 3 A or more (2) STANDARD SIGNAL GENERATOR (SSG) ● Frequency range : 0.1~500 MHz ● Output level : -127~-17 dBm (0.1 μV~32 mV) (3) DISTORTION METER ● Frequency range : 1 kHz±10 Hz ● Measuring range : 1~100% (4) EXTERNAL SPEAKER ● Impedance : 8 Ω (5) DC VOLTMETER ● Input impedance : 50 kΩ/DC or better		<p>To separate the RF UNIT from the MAIN UNIT, see the diagram on the reverse of p. 5-2.</p>				
ADJUSTMENT	ADJUSTMENT CONDITIONS	MEASUREMENT		VALUE	ADJUSTMENT POINT	
		UNIT	LOCATION		UNIT	ADJUST
SENSITIVITY	1	NOTE: When the sensitivity is better than 0.25 μV (12 dB SINAD) on all frequencies, the following sensitivity adjustment is unnecessary. Skip to the S/RF level indicator adjustment (below).				
	<ul style="list-style-type: none"> Frequency: 432.00 MHz 442.00 MHz (USA) Receiving Apply an RF signal to the ANTENNA CONNECTOR. Frequency : 432.00 MHz 442.00 MHz (USA) Level : -119 dBm (0.25 μV) Modulation : 1 kHz Deviation : ±3.5 kHz Squelch control: maximum counter-clockwise 	Side panel	Connect the voltmeter to J2, pin 7.	Peak voltage	RF	L4, L3, L2, L1 (in sequence)
S/RF LEVEL INDICATOR	<ul style="list-style-type: none"> Apply an RF signal to the ANTENNA CONNECTOR: Level : -107 dBm (1.0 μV) Modulation : 1 kHz Deviation : ±3.5 kHz 	Top panel	FUNCTION DISPLAY	Two bars	RF	R4

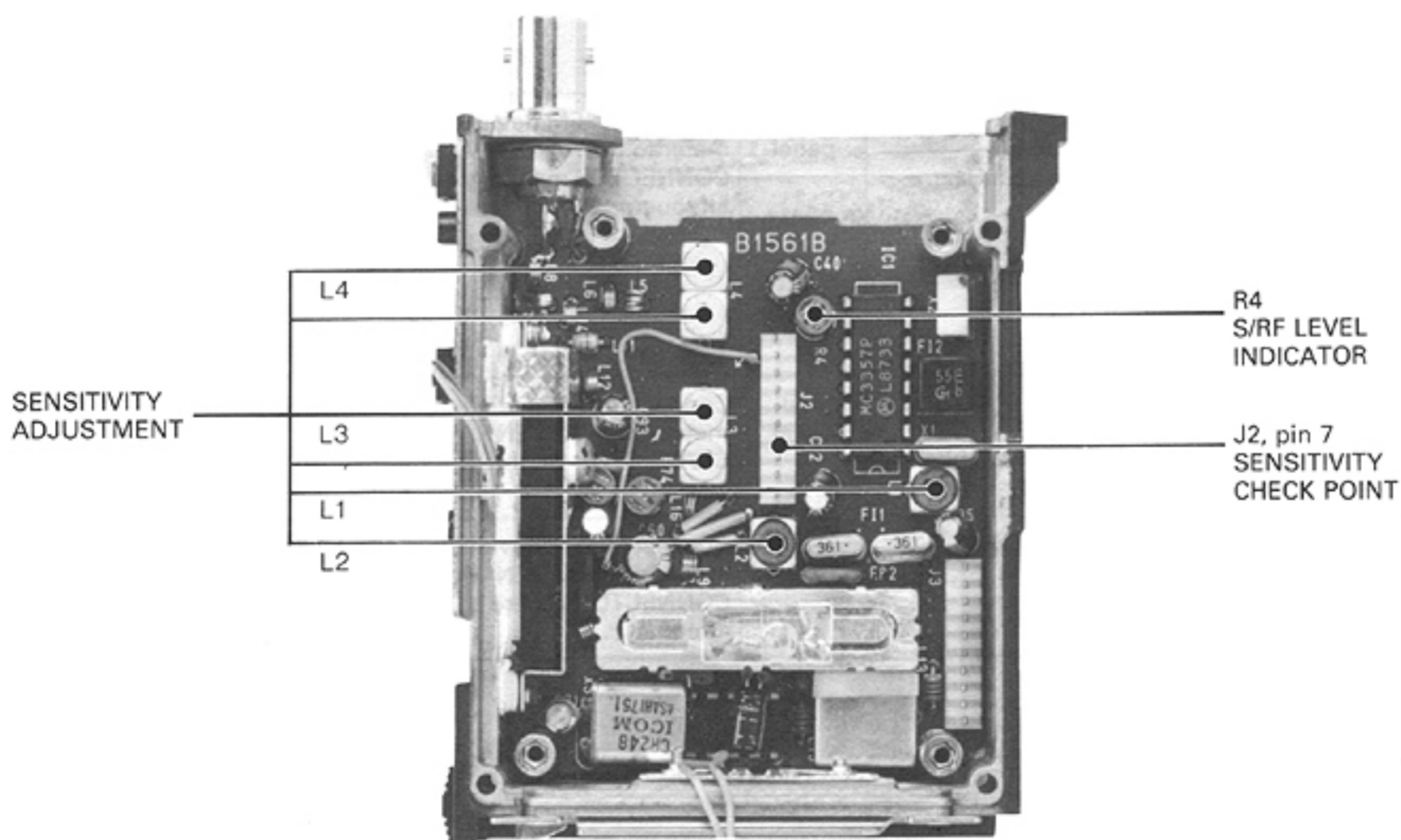

6 - 3 TRANSMITTER ADJUSTMENT

TEST INSTRUMENTS REQUIRED	MEASUREMENT CONNECTION LOCATION
<p>(1) AC POWER SUPPLY</p> <ul style="list-style-type: none"> Output voltage : 8~13.2 V DC (adjustable) Current capacity : 3 A or more <p>(2) RF POWER METER (TERMINATED-TYPE)</p> <ul style="list-style-type: none"> Measuring range : 1~10 W Frequency range : 0.1~500 MHz Impedance : 50 Ω SWR : Less than 1.2:1 <p>(3) AF GENERATOR (AG)</p> <ul style="list-style-type: none"> Frequency range : 200~2000 Hz Output level : 0~200 mV <p>(4) AC MILLI-VOLTMETER</p> <ul style="list-style-type: none"> Measuring range : 2~200 mV <p>(5) FM DEVIATION METER</p> <ul style="list-style-type: none"> Minimum frequency : 500 MHz Measuring range : ±10 kHz <p>(6) ATTENUATOR</p> <ul style="list-style-type: none"> Attenuation ratio : 30 or 40 dB 	<p>To separate the RF UNIT from the MAIN UNIT, see the diagram on the reverse of p. 5-2.</p>

ADJUSTMENT	ADJUSTMENT CONDITIONS	MEASUREMENT		VALUE	ADJUSTMENT POINT	
		UNIT	LOCATION		UNIT	ADJUST
OUTPUT POWER	<ul style="list-style-type: none"> Frequency: 435.00 MHz 445.00 MHz (USA) Output power: HIGH Transmit 	Top panel	Connect the RF power meter to the ANTENNA CONNECTOR.	6 W	RF	R71
	<ul style="list-style-type: none"> Output power: LOW 			1 W	RF	R74
	<ul style="list-style-type: none"> Power supply output voltage: 9 V DC Output power: HIGH 			More than 2.5 W		Verify
	<ul style="list-style-type: none"> Power supply output voltage: 8.4 V DC Output power: HIGH 			More than 2.0 W		Verify
FM DEVIATION	<ul style="list-style-type: none"> Frequency: 435.00 MHz 445.00 MHz (USA) FM deviation meter: HPF : 50 kHz LPF : 20 kHz Deemphasis: OFF Detector : (P-P)/2 Apply an AF signal to the EXT. MIC JACK: 1 kHz, 40 mV (USA version: 1 kHz, 100 mV) 	Top panel	Connect the FM deviation meter to the ANTENNA CONNECTOR via the attenuator.	±4.8 kHz	MAIN	R241
CTCSS DEVIATION (IC-4GAT only)	<ul style="list-style-type: none"> Frequency: 435.00 MHz 445.00 MHz (USA) Set the tone frequency to 88.5 Hz. HPF : OFF LPF : 20 kHz De-emphasis : OFF Detector : (P-P)/2 Cut off microphone input Transmit 	Top panel	Connect the FM deviation meter to the ANTENNA CONNECTOR via the attenuator.	±0.75 kHz	TONE	R601
DTMF DEVIATION (IC-4GAT only)	<ul style="list-style-type: none"> Frequency: 435.00 MHz 445.00 MHz (USA) While pushing the [PTT] switch; push and hold "D" on the keypad. 	Top panel	Connect the FM deviation meter to the ANTENNA CONNECTOR via the attenuator.	±3.5 kHz	DTMF	R801
TONE CALL DEVIATION (IC-4GE only)	<ul style="list-style-type: none"> Frequency: 435.00 MHz Push and hold [T. CALL]. 	Top panel	Connect the FM deviation meter to the ANTENNA CONNECTOR via the attenuator.	±3.5 kHz	MAIN	R242

**MAIN AND TONE UNITS
IC-4GA, IC-4GAT**

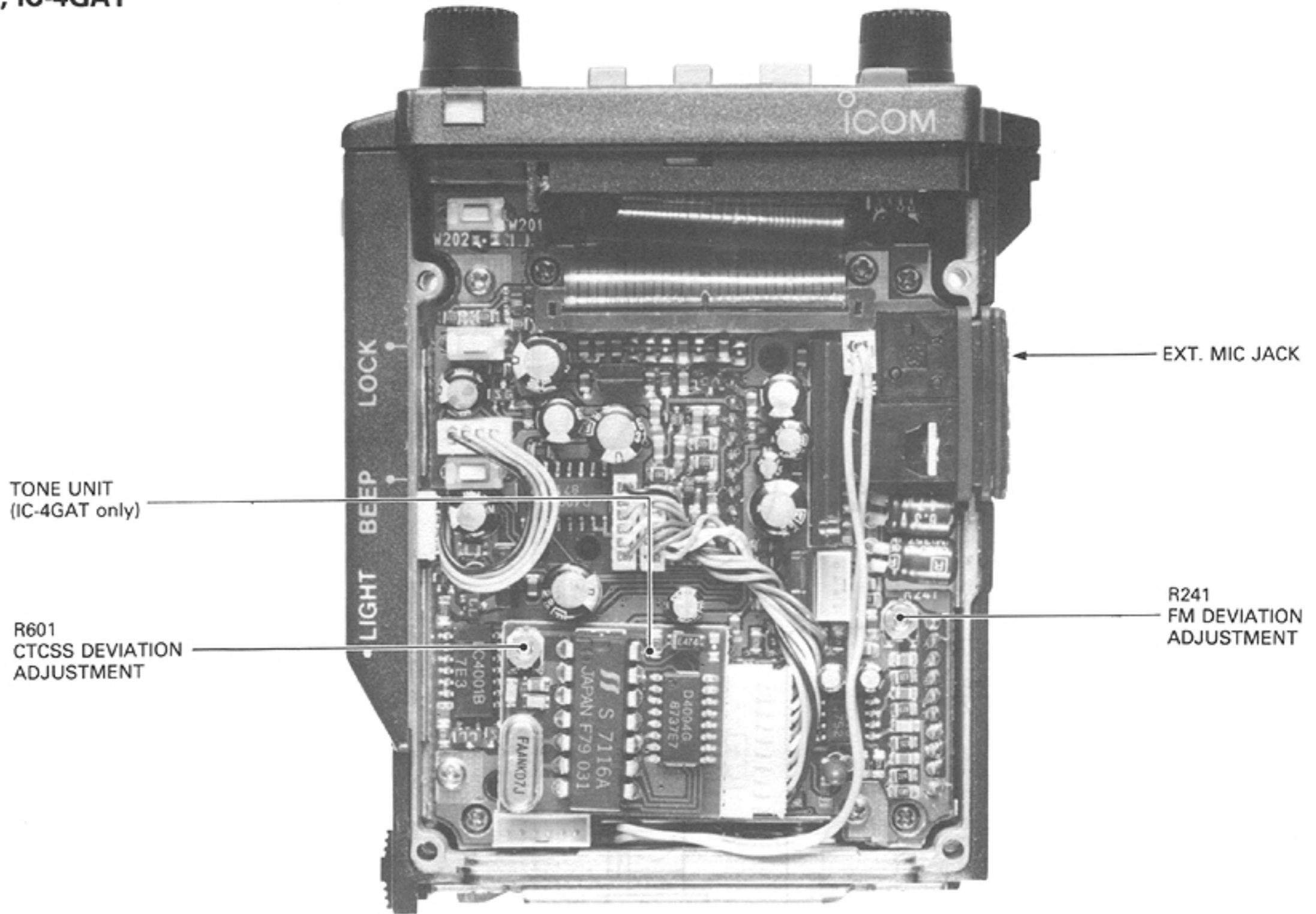

IC-4GE

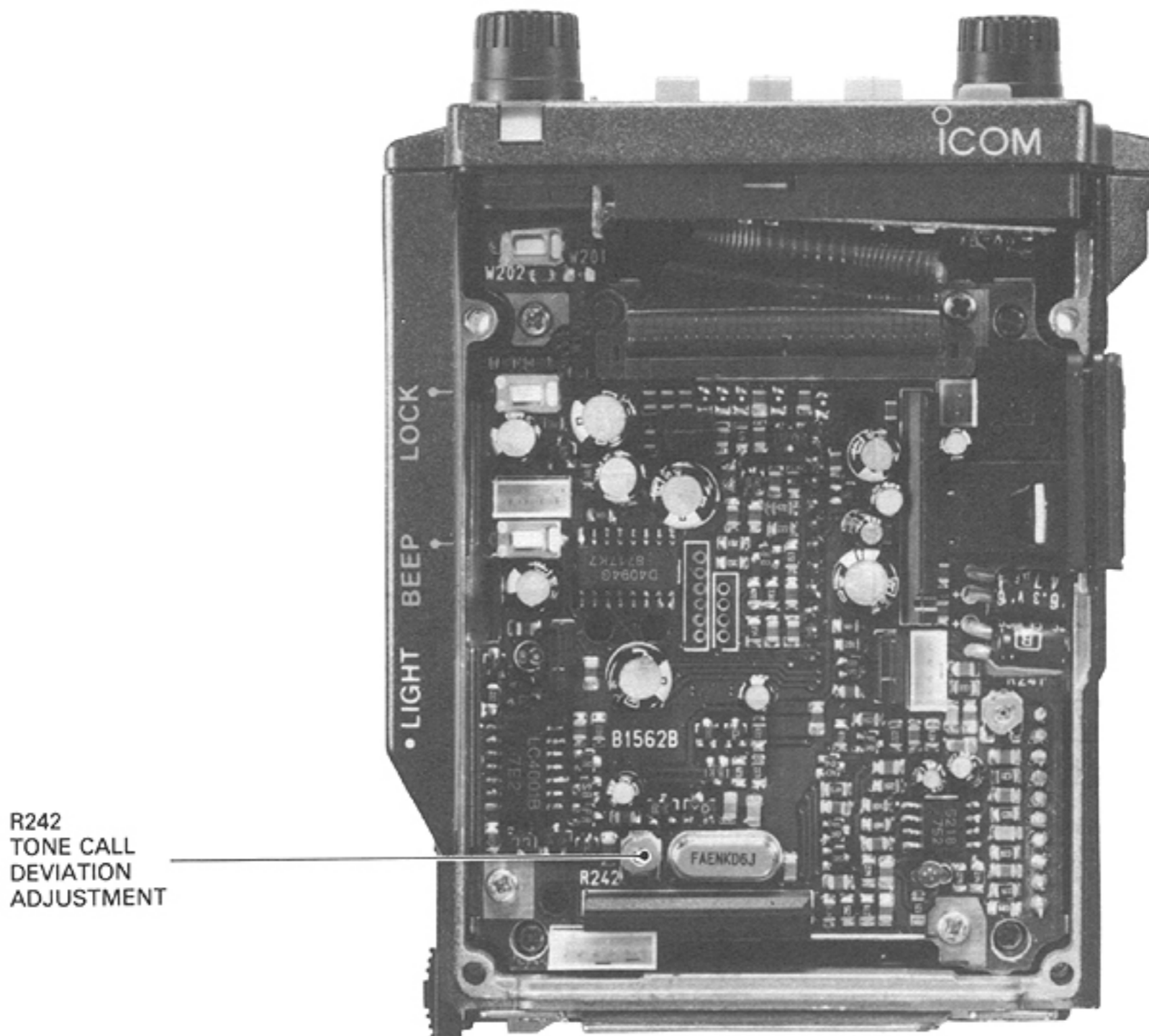

RF UNIT

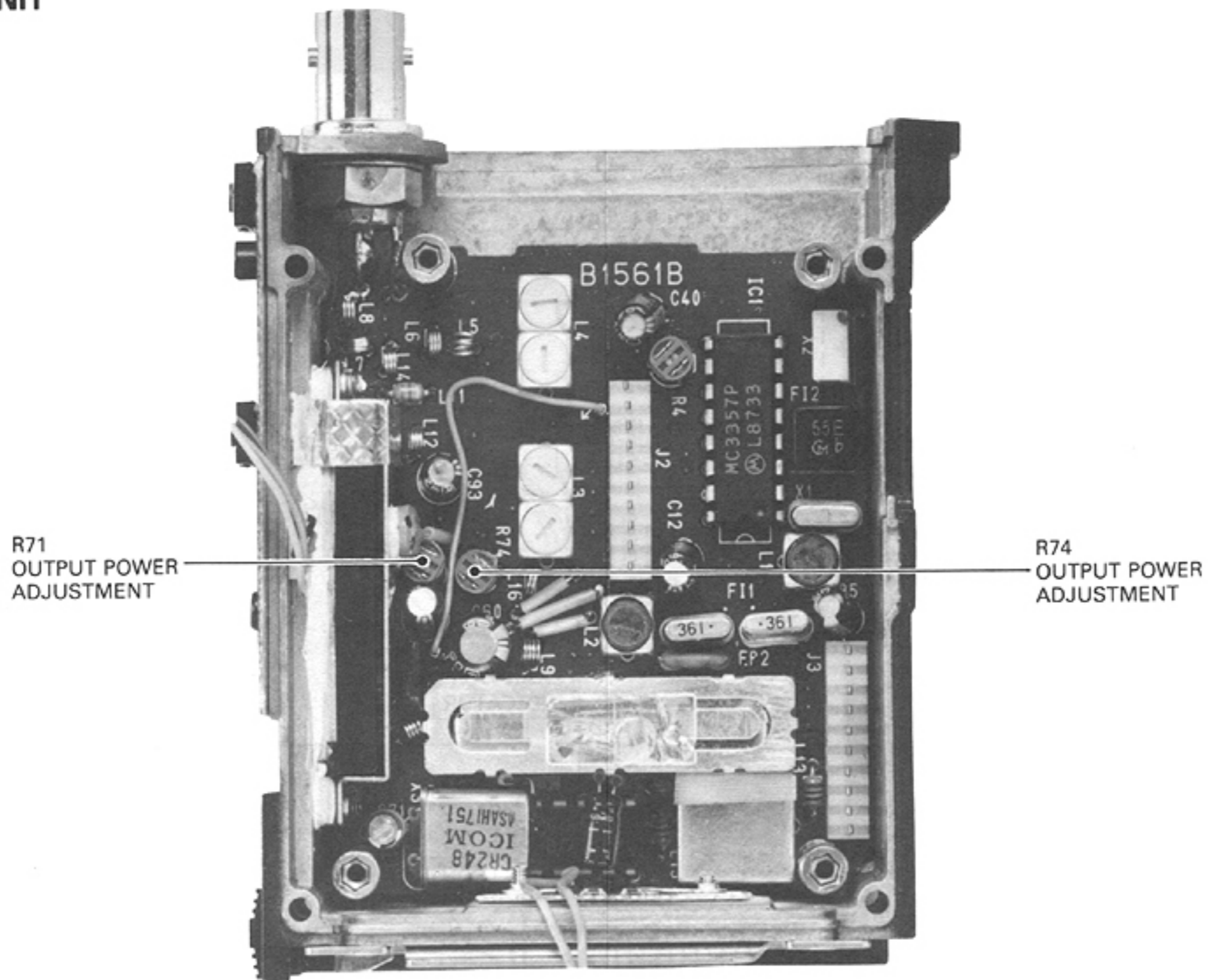

SPEAKER AND DTMF UNITS

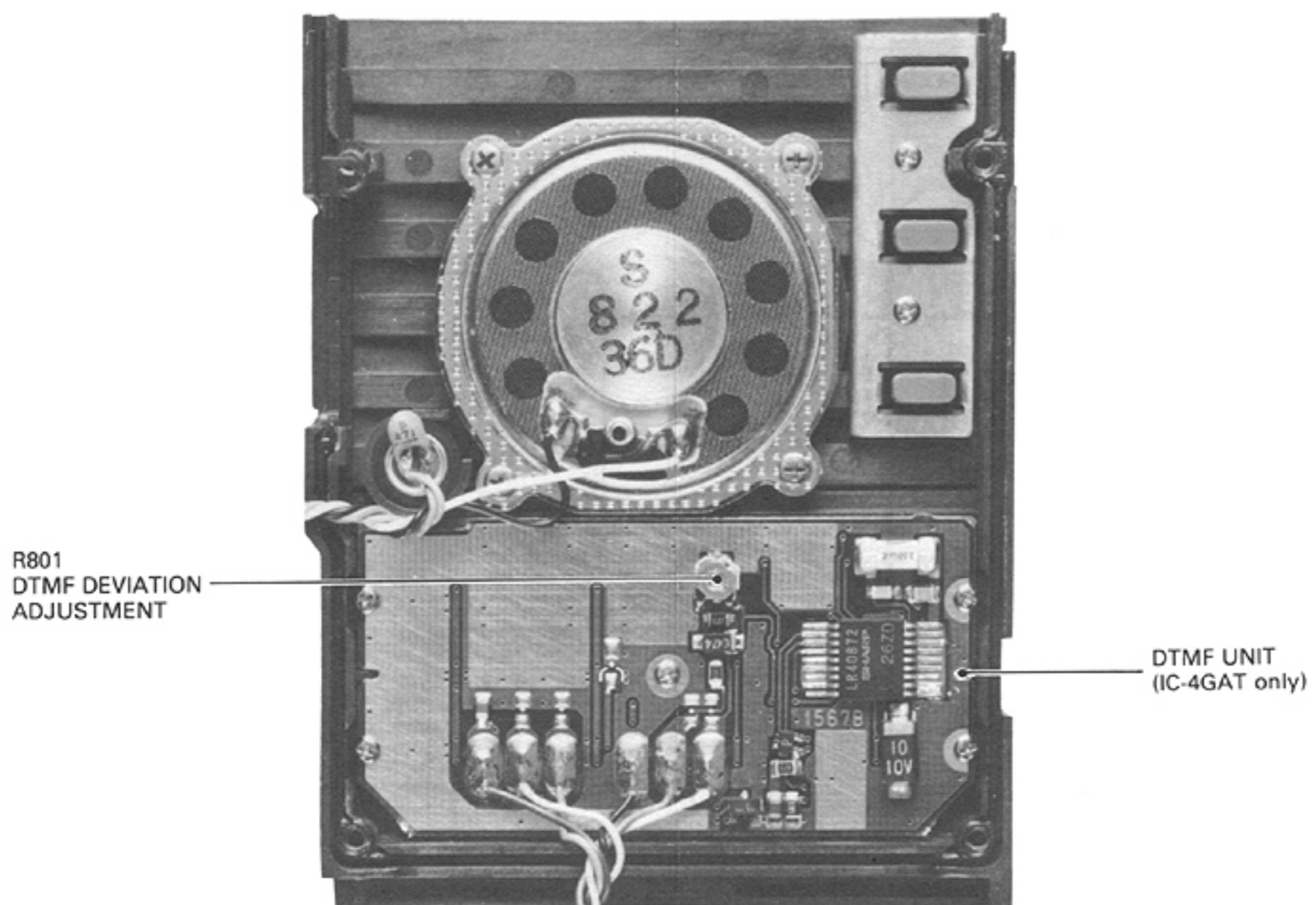

7 - 1 INTERCONNECTION

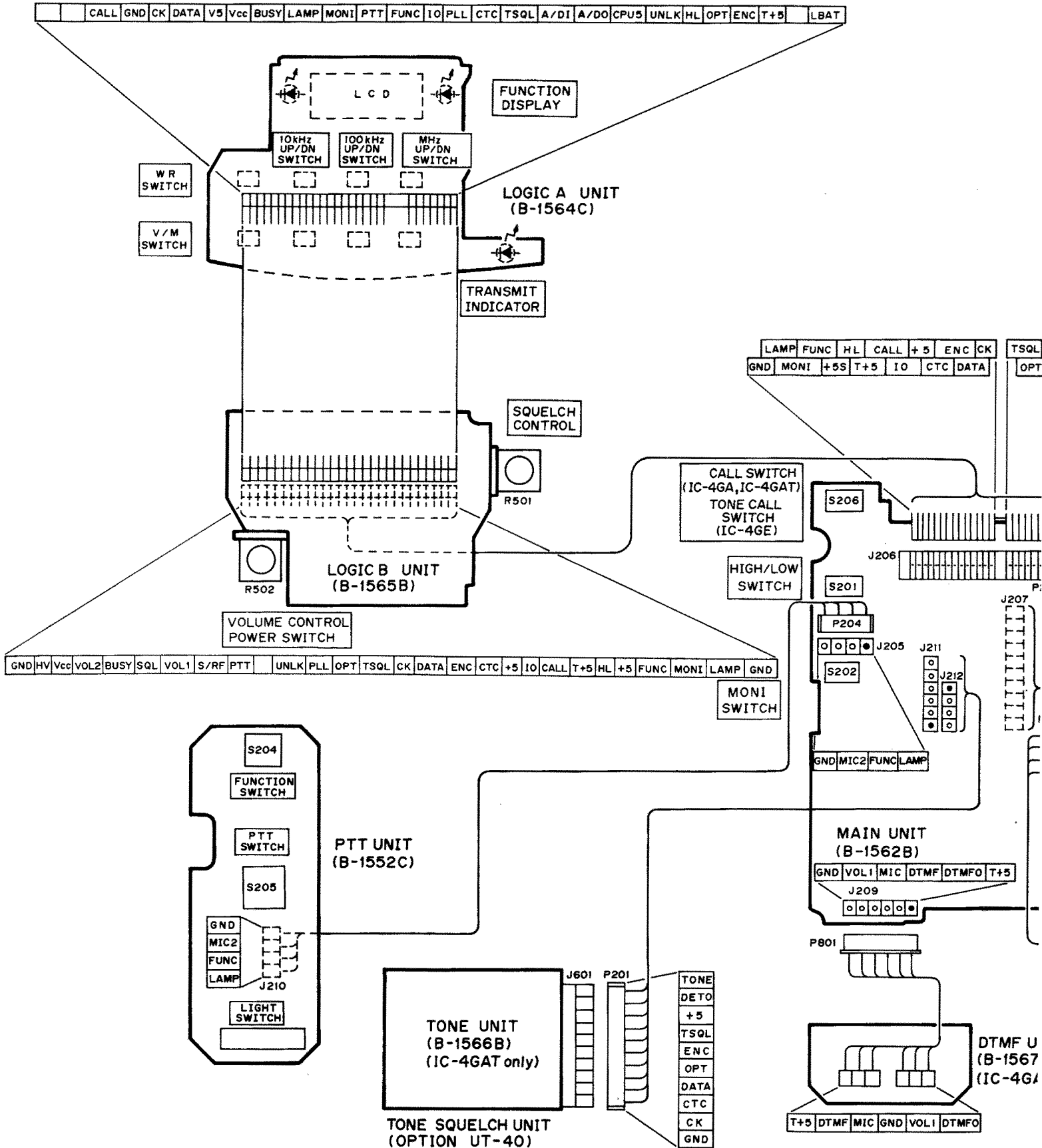

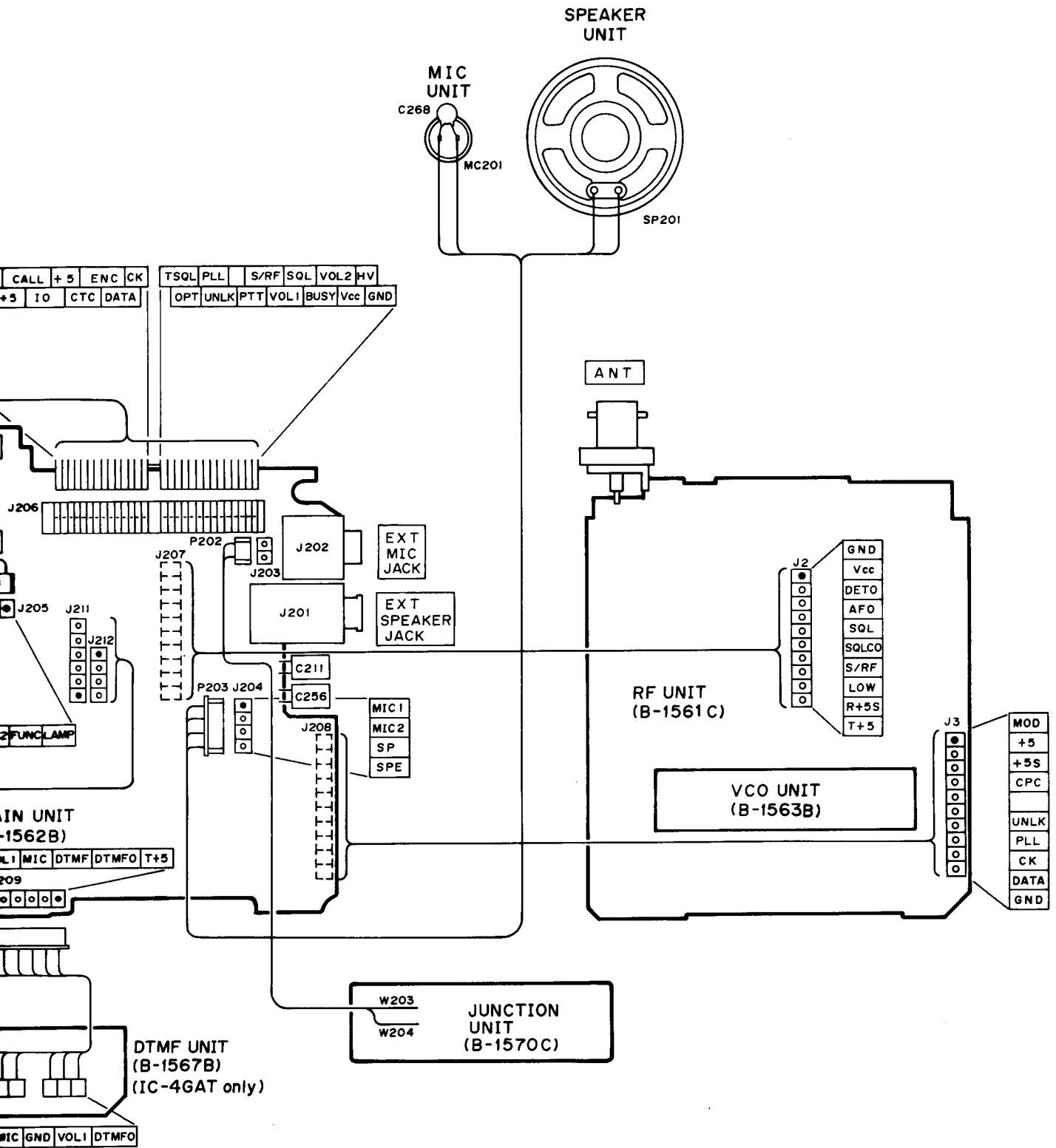

7 - 2 LOGIC-A UNIT

COMPONENT SIDE

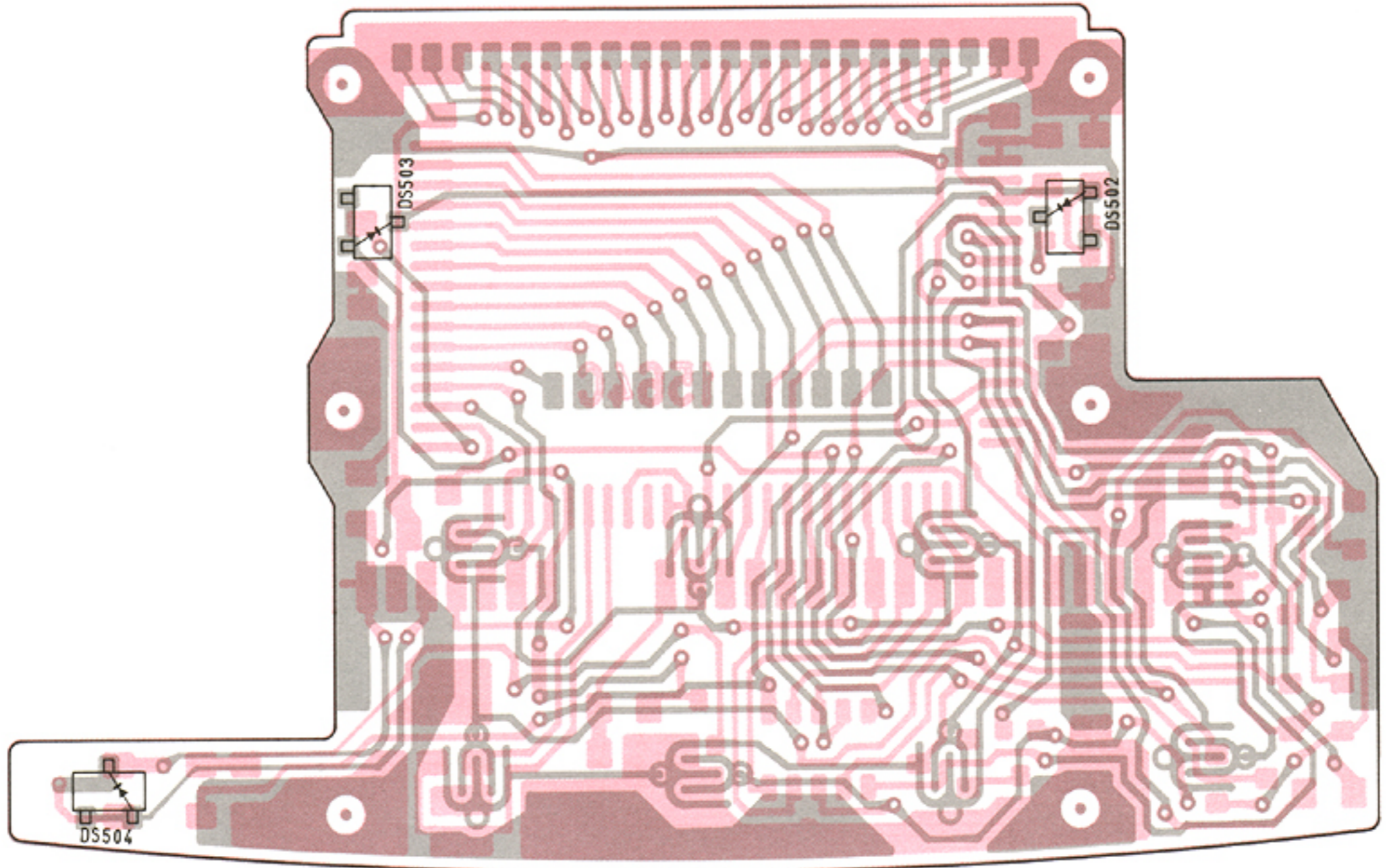

μPD75308GF-034-3B9 IC503 (CPU)

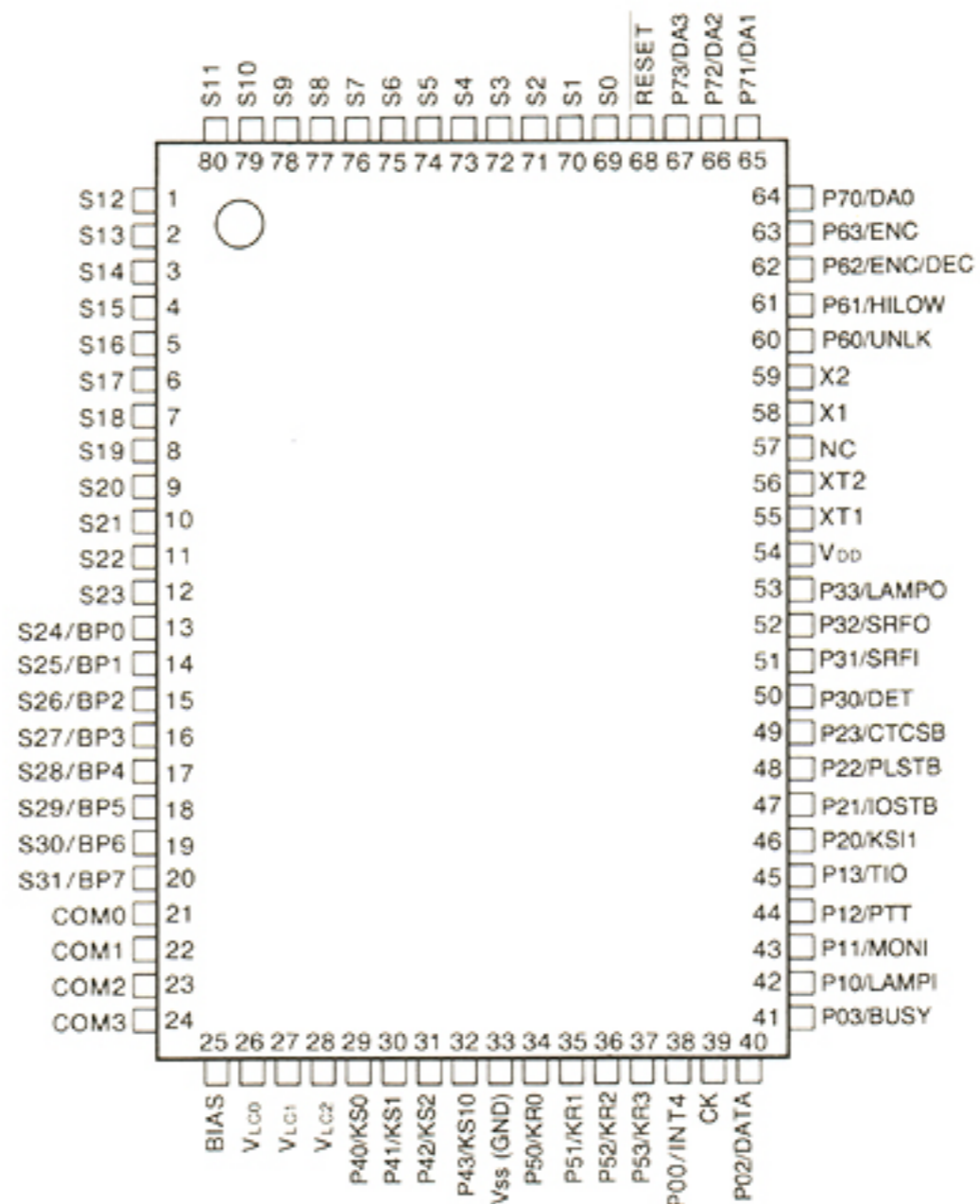

FOIL SIDE

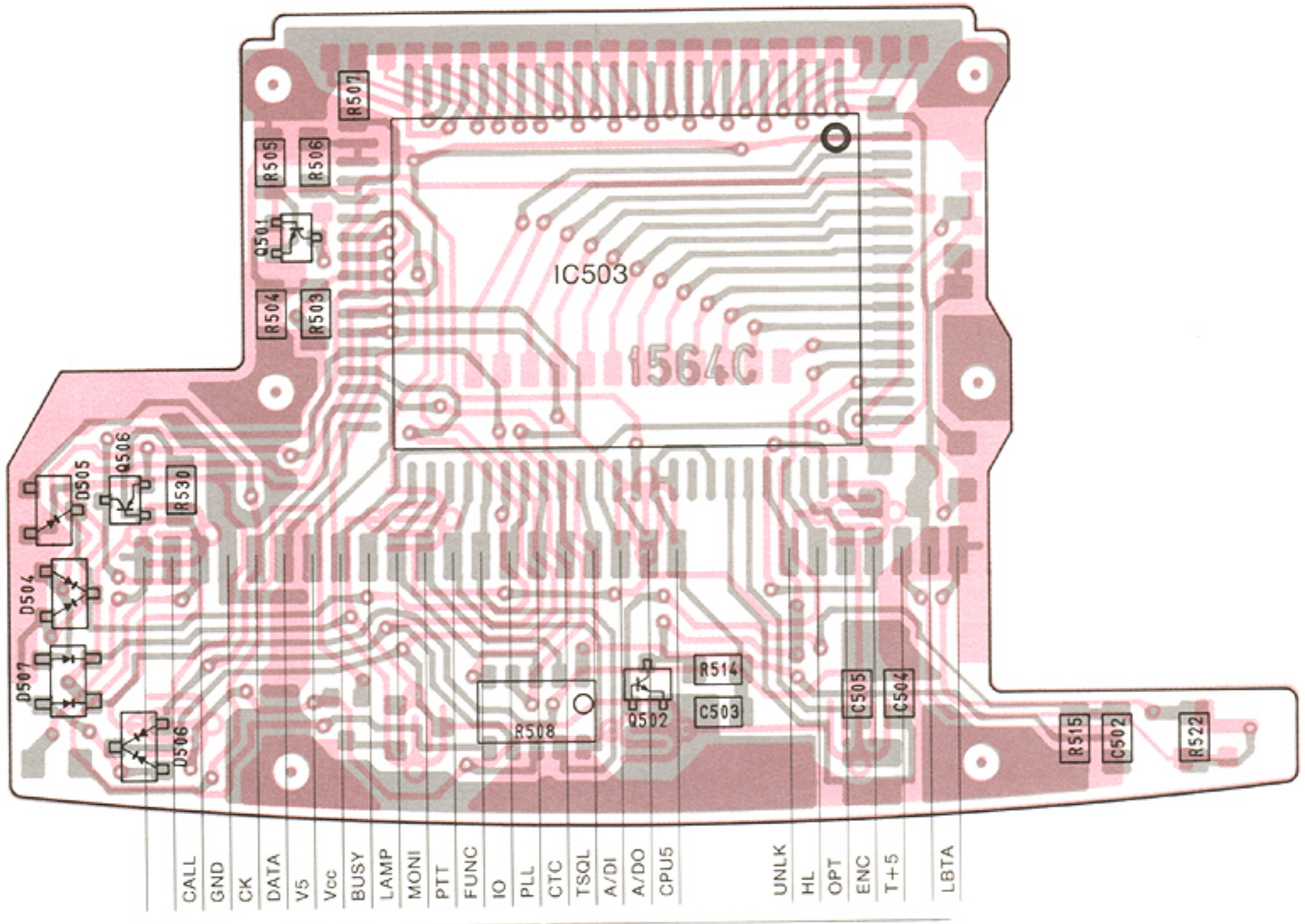

CALL GND CK DATA V5 Vcc BUSY LAMP MONI PTT FUNC IO PLL CTC TSQL A/DI A/DO CPU5 UNLK HL OPT ENC T+5 LBTA

TO LOGIC (B)UNIT

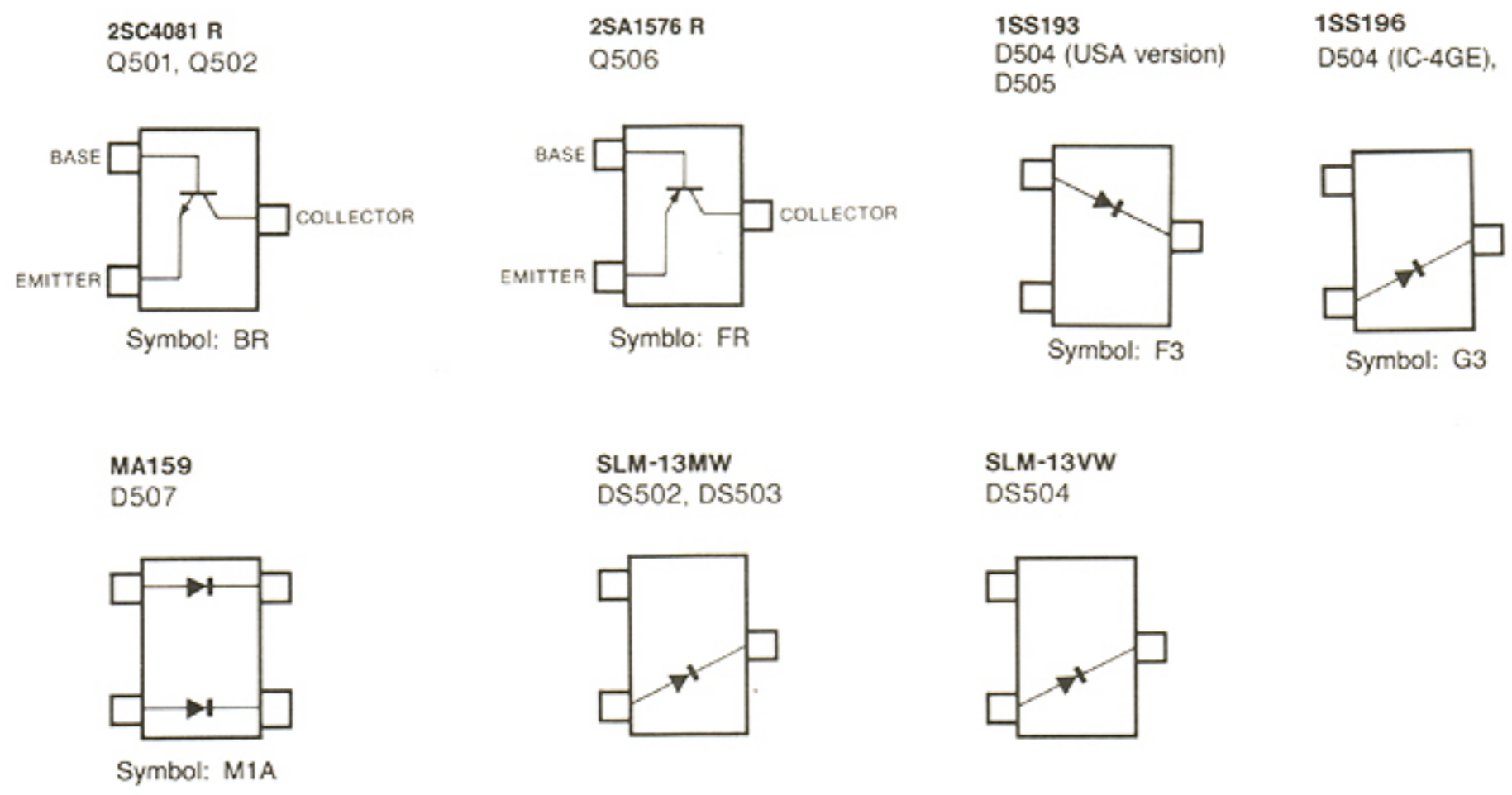

7 - 3 LOGIC-B UNIT

COMPONENT SIDE

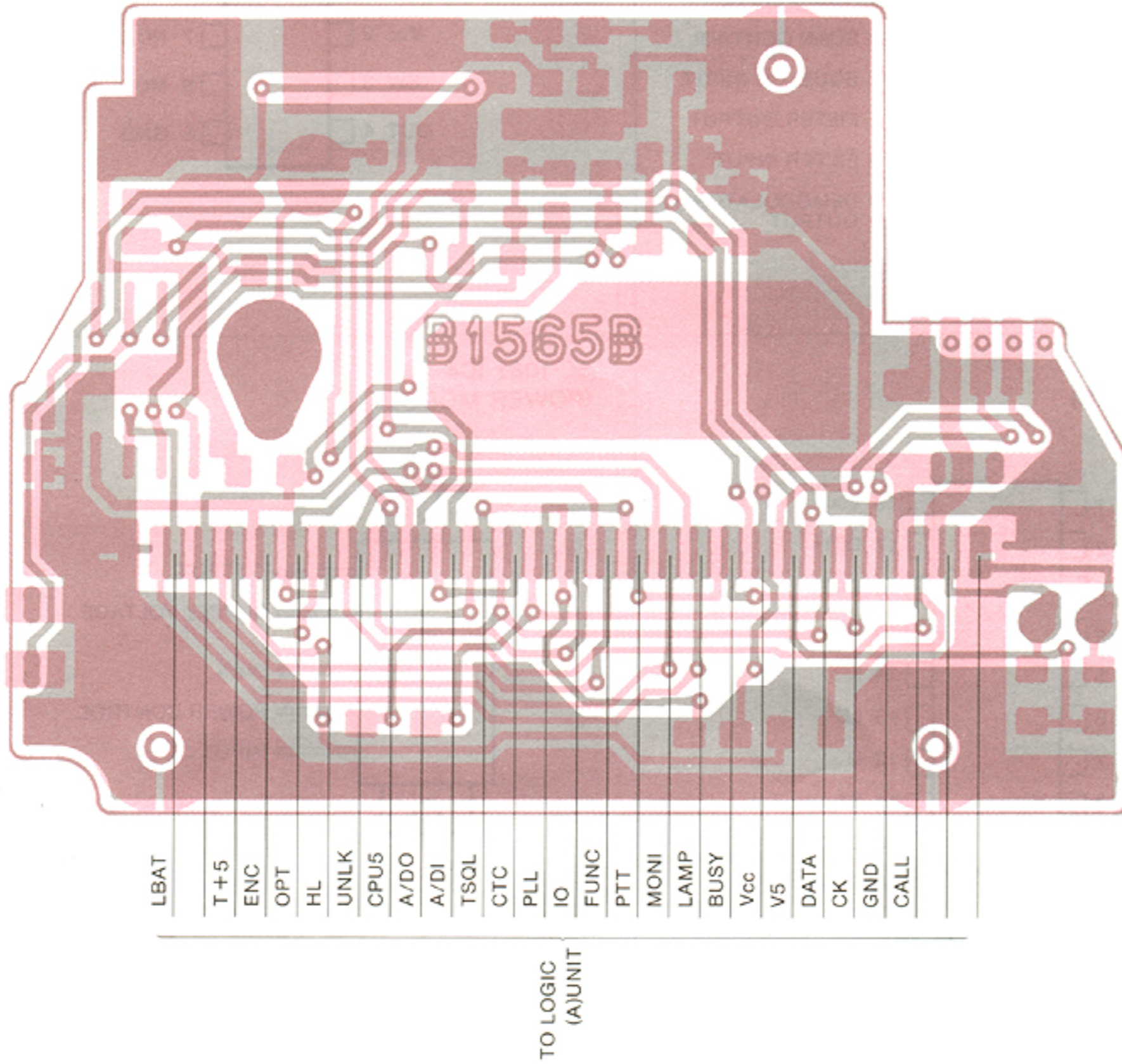

S-8054ALB IC501
(RESET)

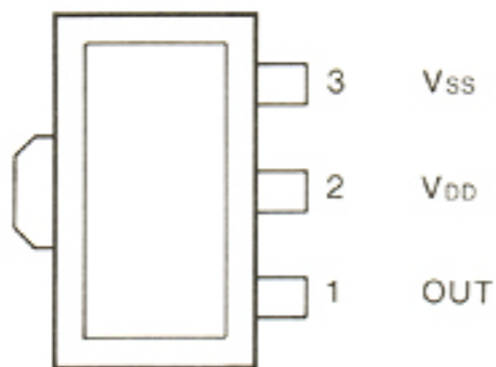

LA6393M IC502
(DUAL COMPARATOR)

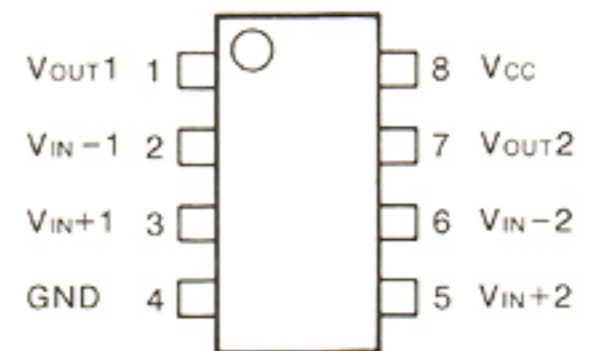

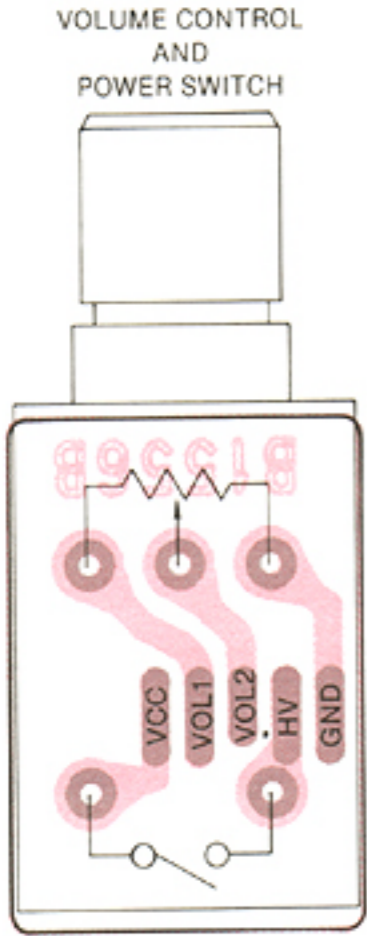

FOIL SIDE

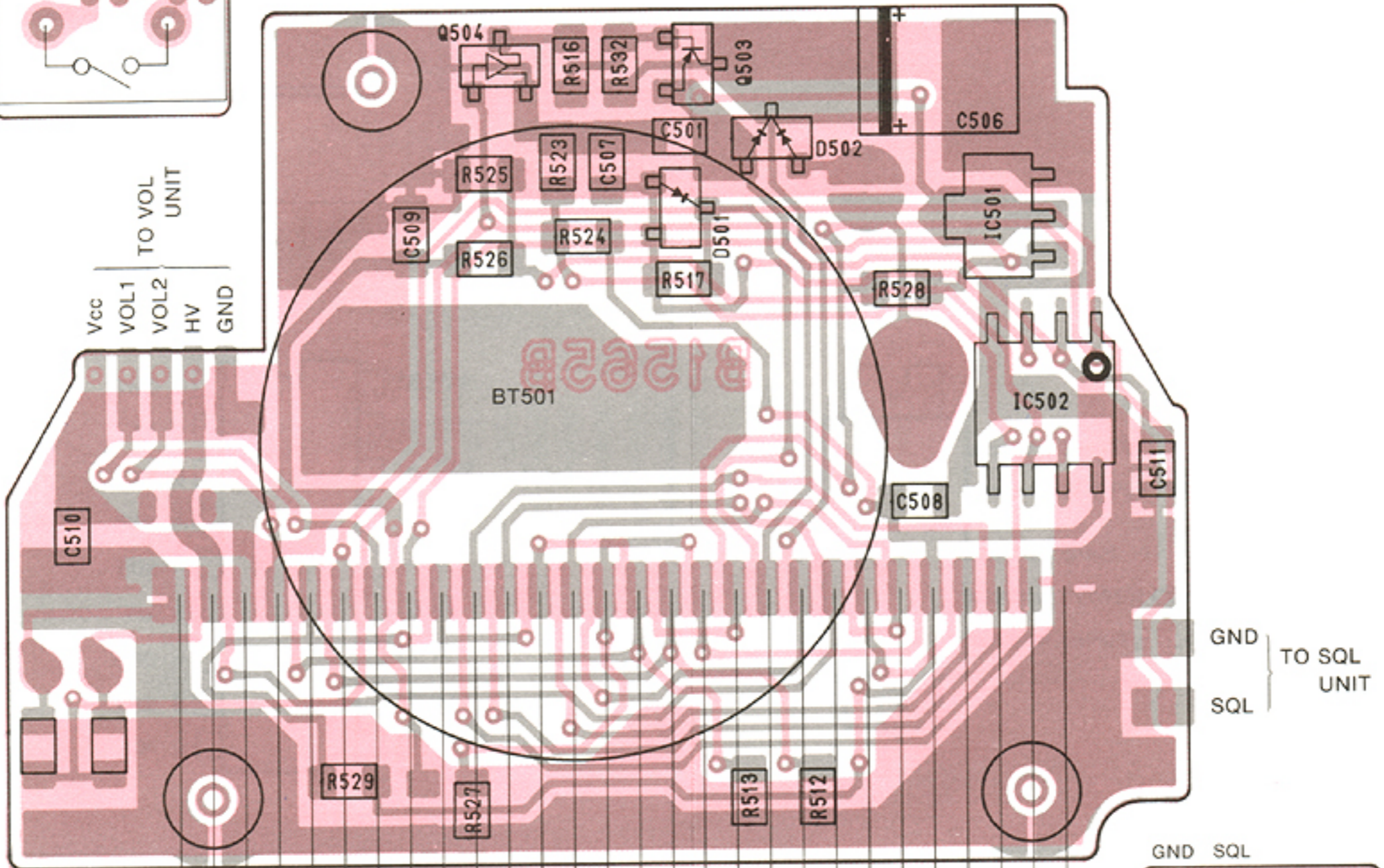

GND HV Vcc VOL2 BUSY SQL VOL1 S/RF PTT UNLK PLL OPT TSQL CK DATA ENC CTC +5 IO CALL T+5 HL +5S FUNC MONI LAMP GND

TO MAIN UNIT J208

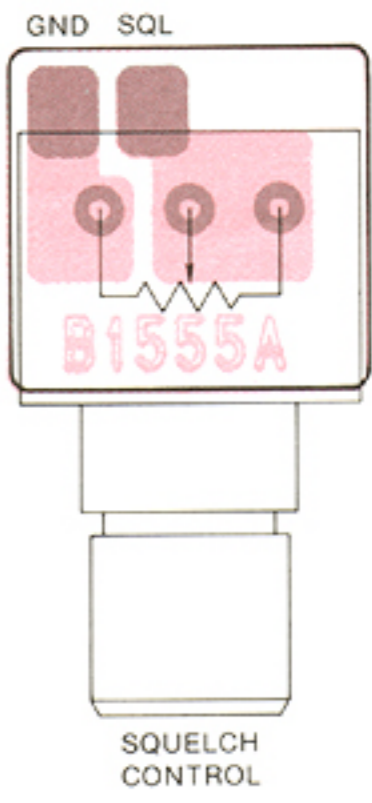

2SA1362 GR Q503

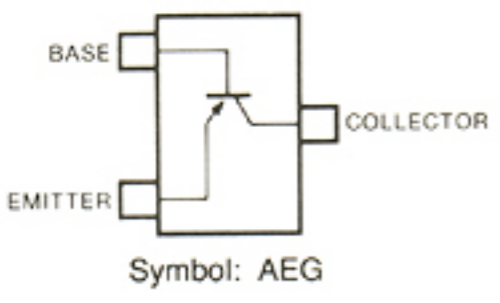

RN1404 Q504

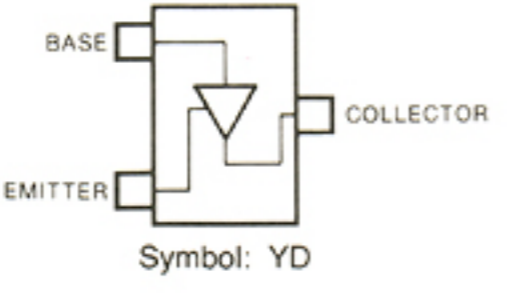

1SS184 D502

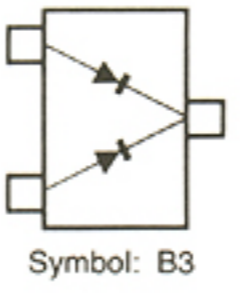

1SS193 D501,

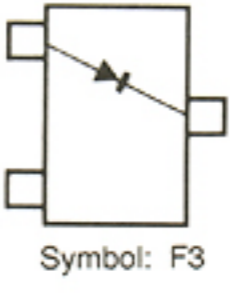

7 - 4 RF UNIT

MC3357P IC1
(LOW POWER FM IF)

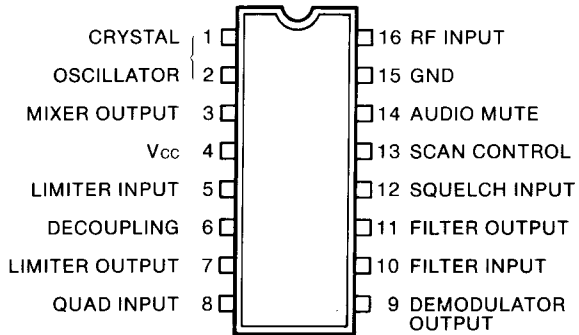

MB504LP IC2
(PRESCALER)

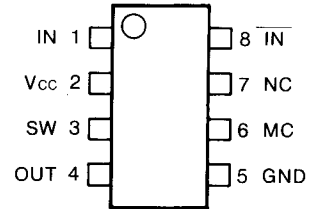

TC9181P IC3
(PLL SYNTHESIZER)

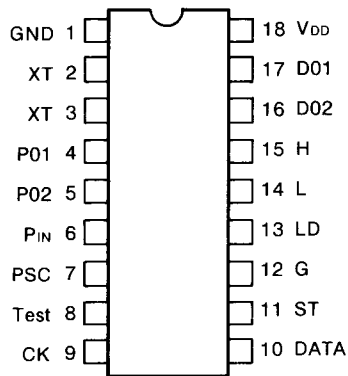

SC-1081 IC4
(POWER MODULE)

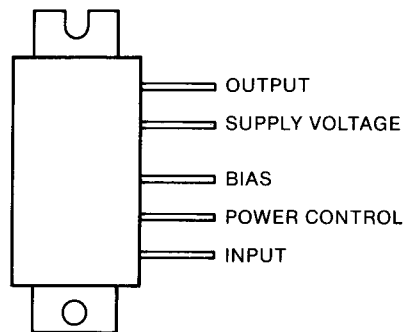

FOIL SIDE

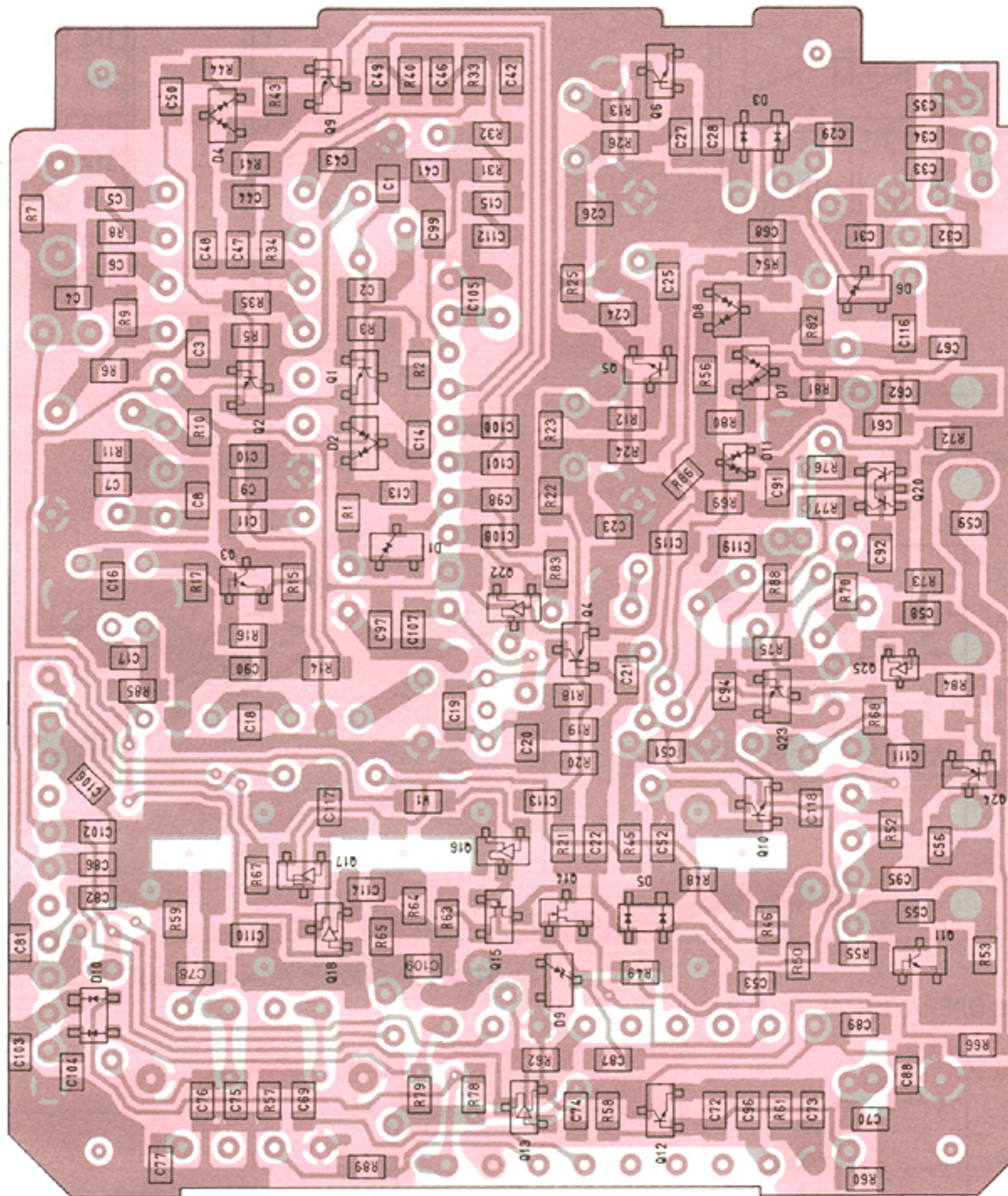

2SC3770 3
Q1, Q2, Q3

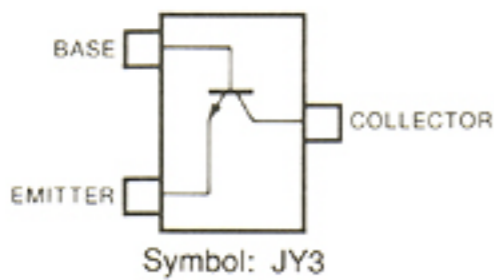

2SC3772 3
Q4, Q5, Q6
Q10, Q11

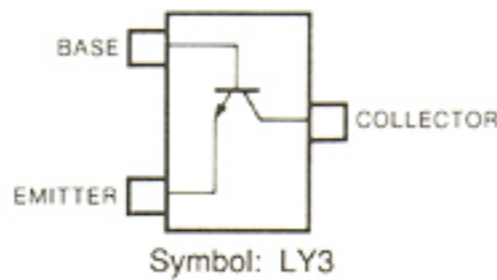

2SC2712 BL
Q9, Q12, Q23

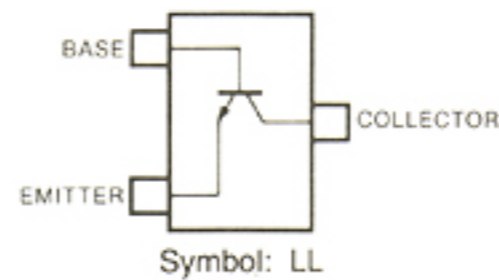

RN1404
Q13, Q16, Q18
Q22

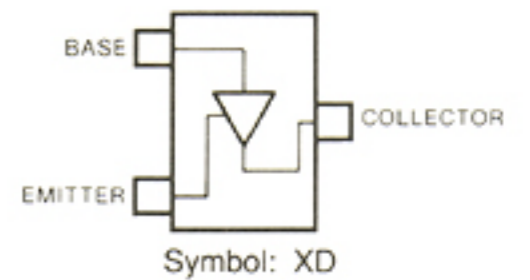

2SB909M
Q19

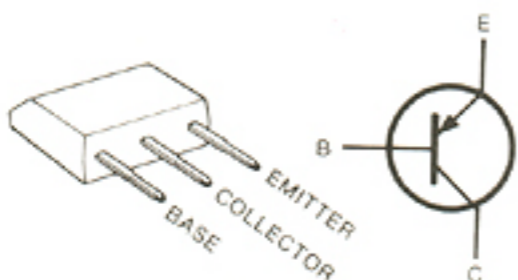

1SS193
D1

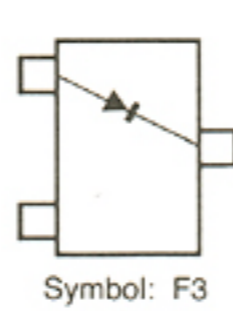

HSM88AS
D2, D4, D7
D8

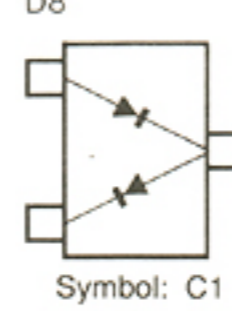

MA862
D3, D5

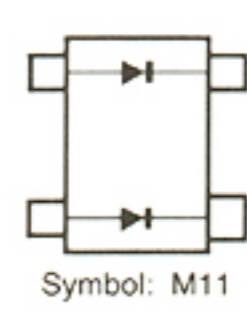

COMPONENT SIDE

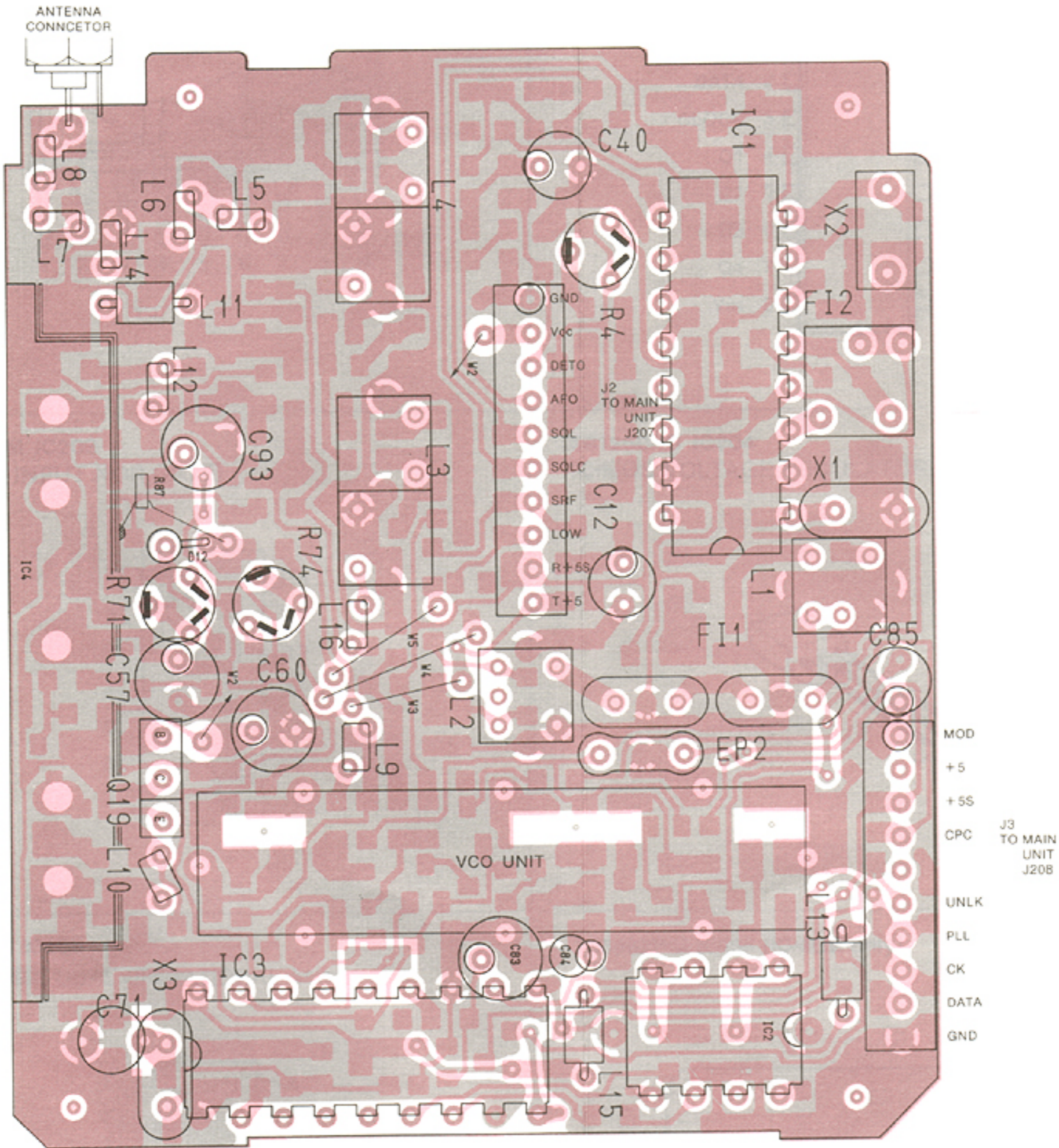

2SK536
Q14, Q15

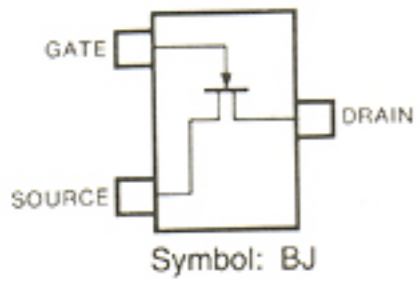

RN2404
Q17

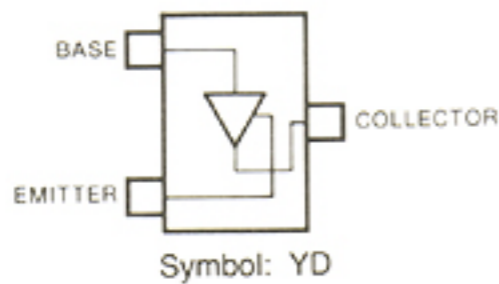

FMS1
Q20

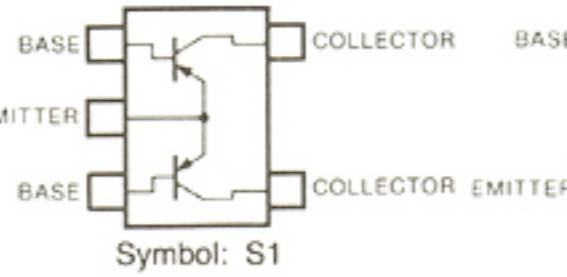

2SA1298 Y
Q24

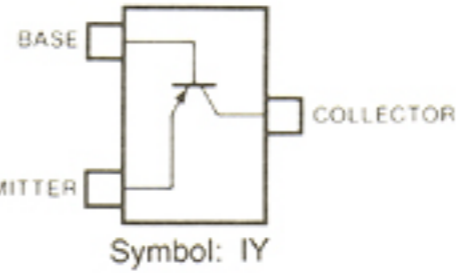

DTC114EU
Q25

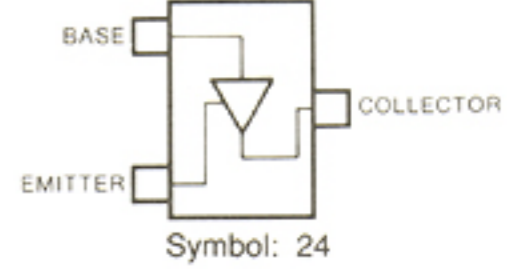

1SS153
D6



RD9.1M
D9

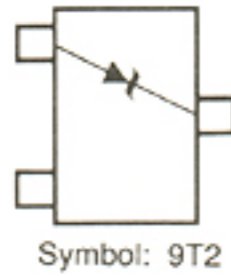

MA159
D10

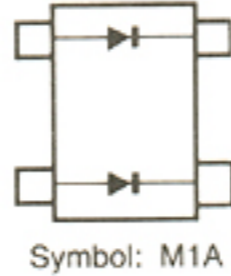

DAP202U
D11

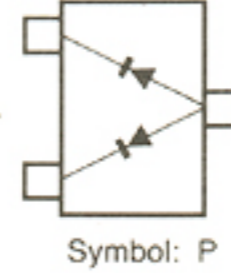

7 - 5 MAIN UNIT

BA526 IC201
(SINGLE POWER AMPLIFIER)

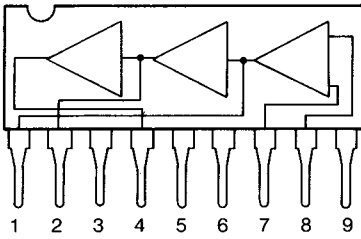

μ PD4094BG IC202
(8 STAGE SHIFT/STORE BUS REGISTER)

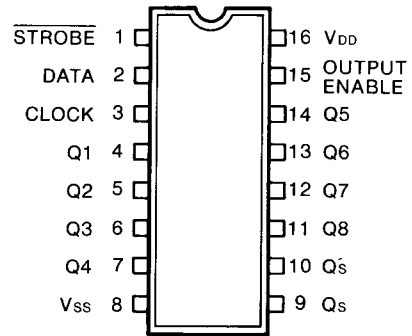

LC4001BM IC203
(QUAD 2 INPUT NOR GATE)

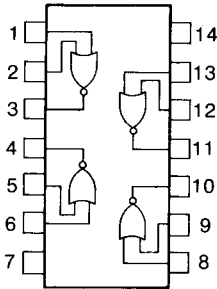

S81250HG IC204
(C-MOS VOLTAGE REGULATOR)

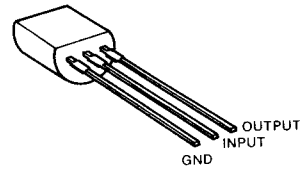

M5218FP IC205
(LOW NOISE DUAL OPERATIONAL AMPLIFIER)

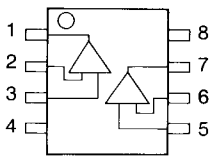

TC5082P-G IC206 (IC-4GE only)

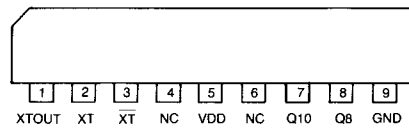

FOIL SIDE

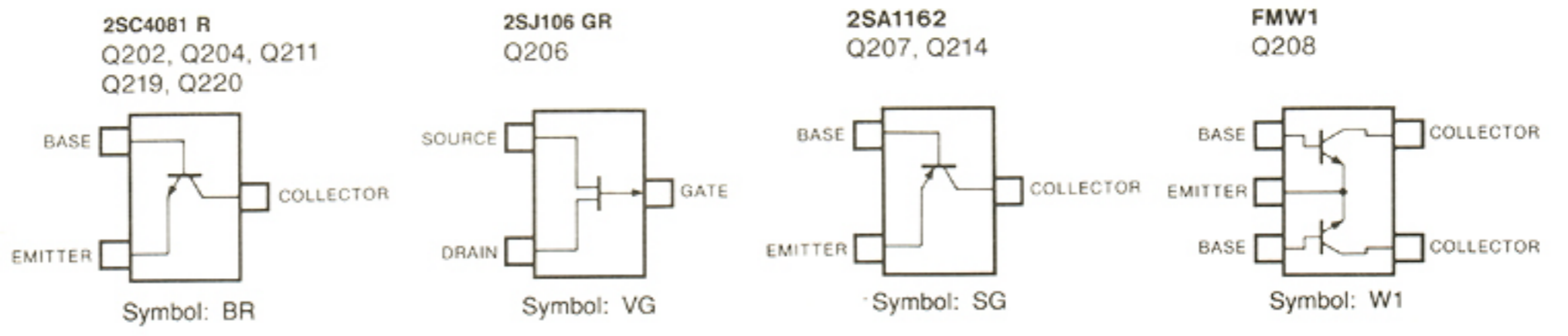
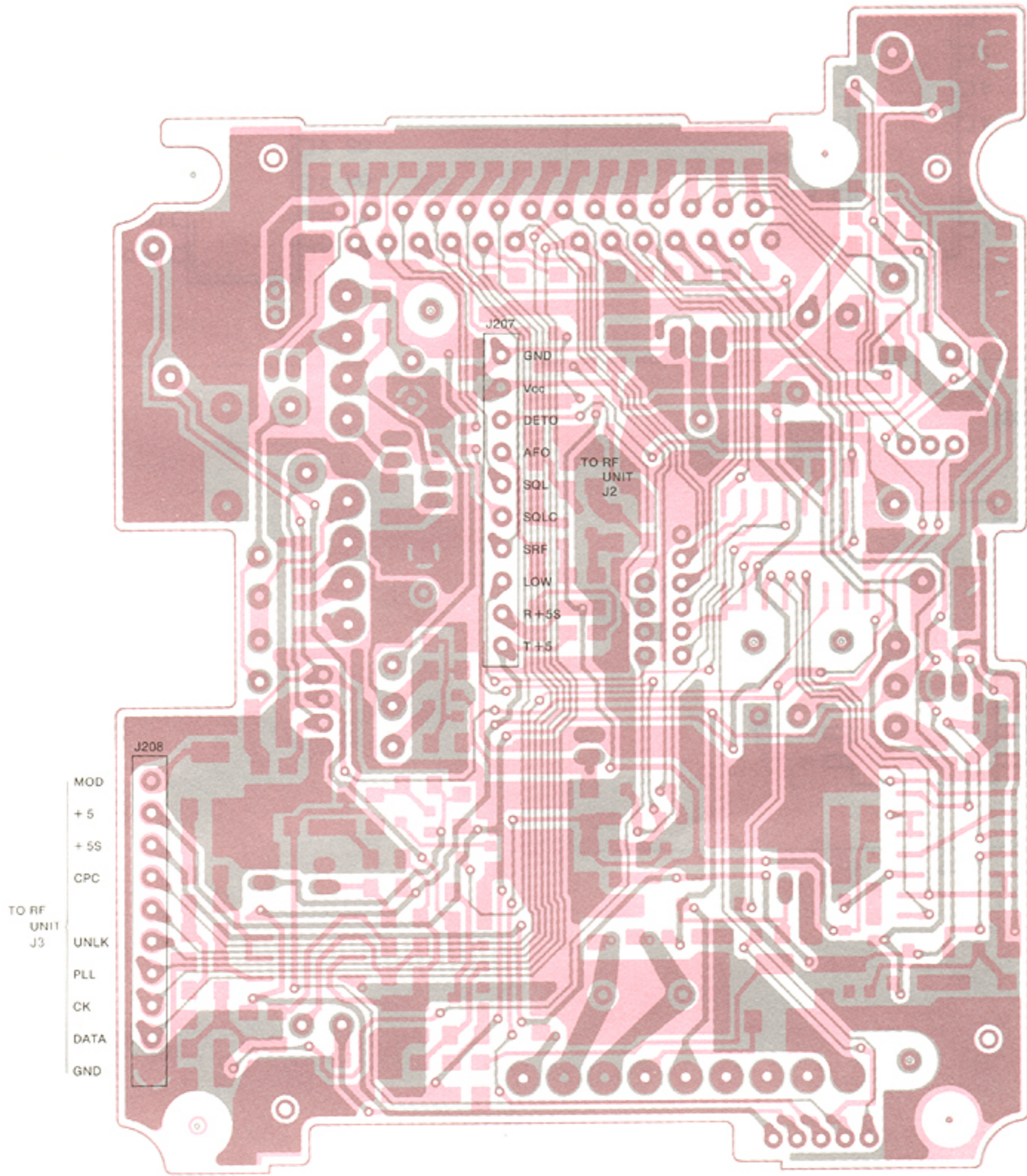

COMPONENT SIDE

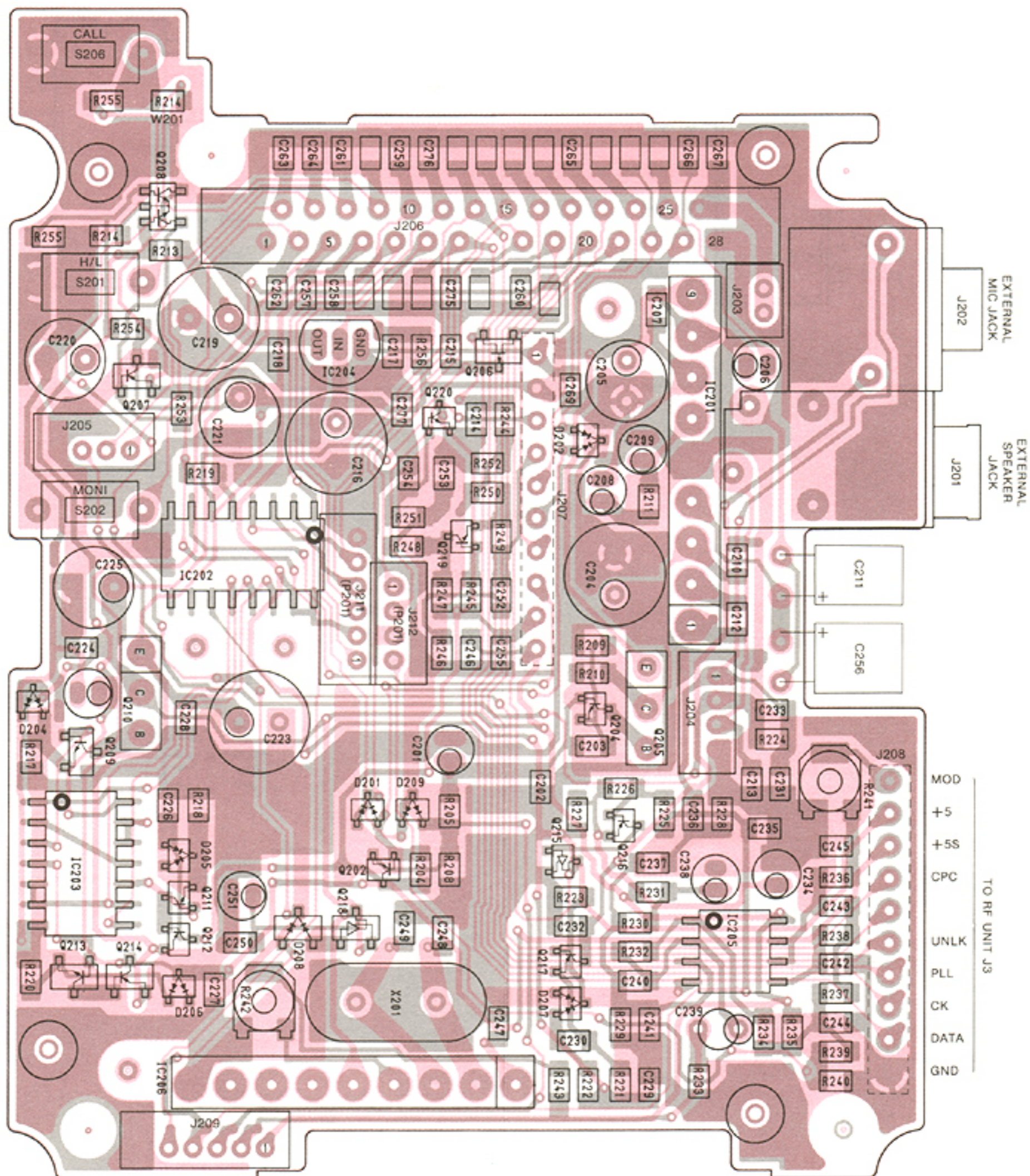

2SC2712 BL
Q209, Q213

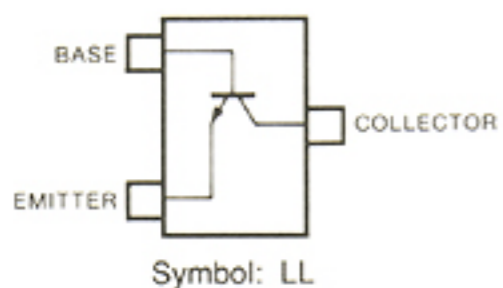

2SA1576 R
Q212, Q216, Q217

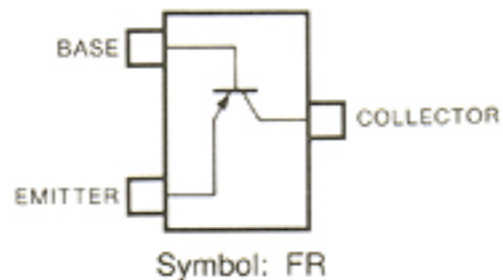

2SB909M
Q205, Q210

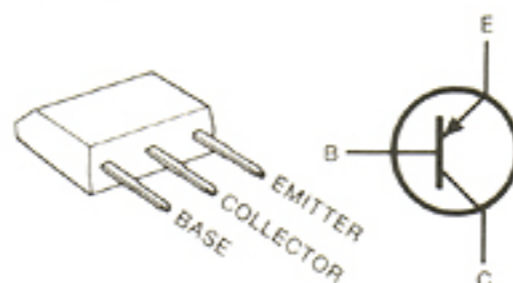

DAN202U
D201, D202, D205
D207

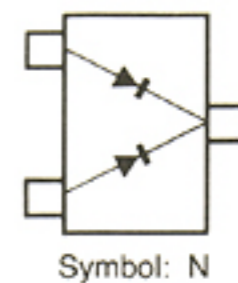

DAP202U
D204, D206, D209

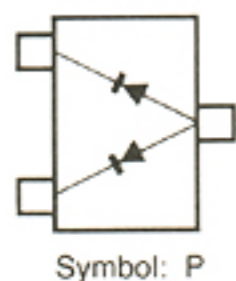

DTC144EU
Q215

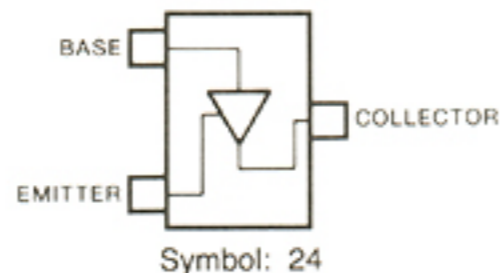

RN2404
Q218 (IC-4GE only)

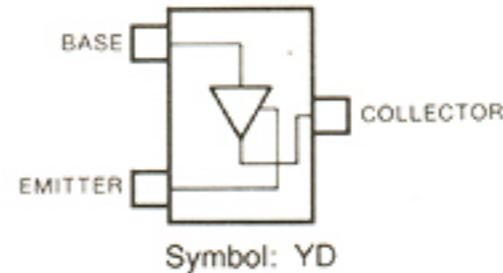

1SS184
D208 (IC-4GE only)

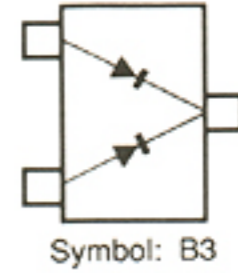

7 - 6 OTHER UNITS

S7116A IC601

(TONE GENERATOR C-MOS LSI)

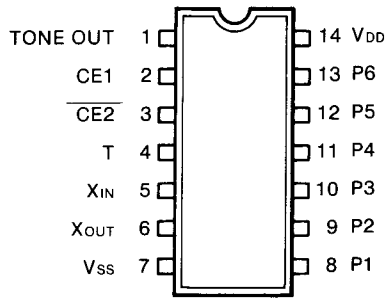

μPD4094BG IC602

(8 STAGE SHIFT/STORE BUS REGISTER)

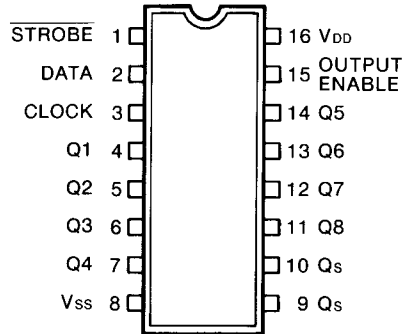

LR40872 IC801

(TONE DIALING)

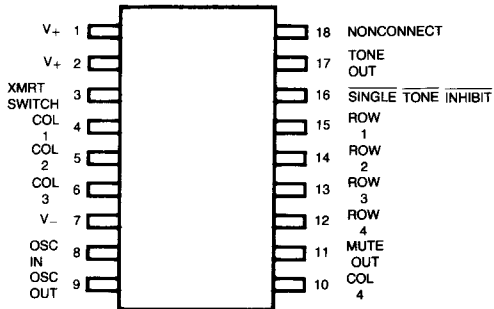

• VCO UNIT

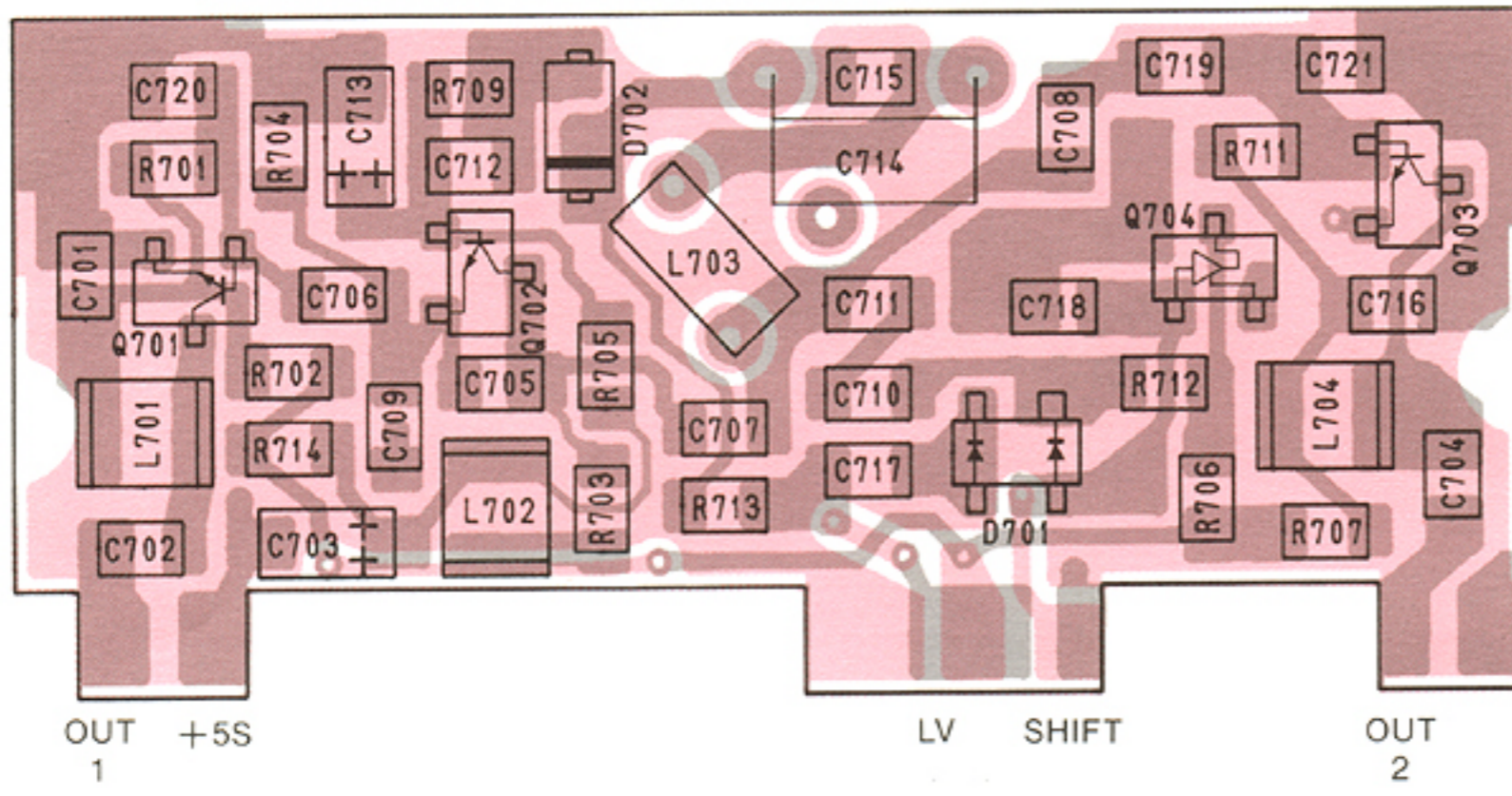

OUT 1 +5S

LV SHIFT

OUT 2

• PTT UNIT

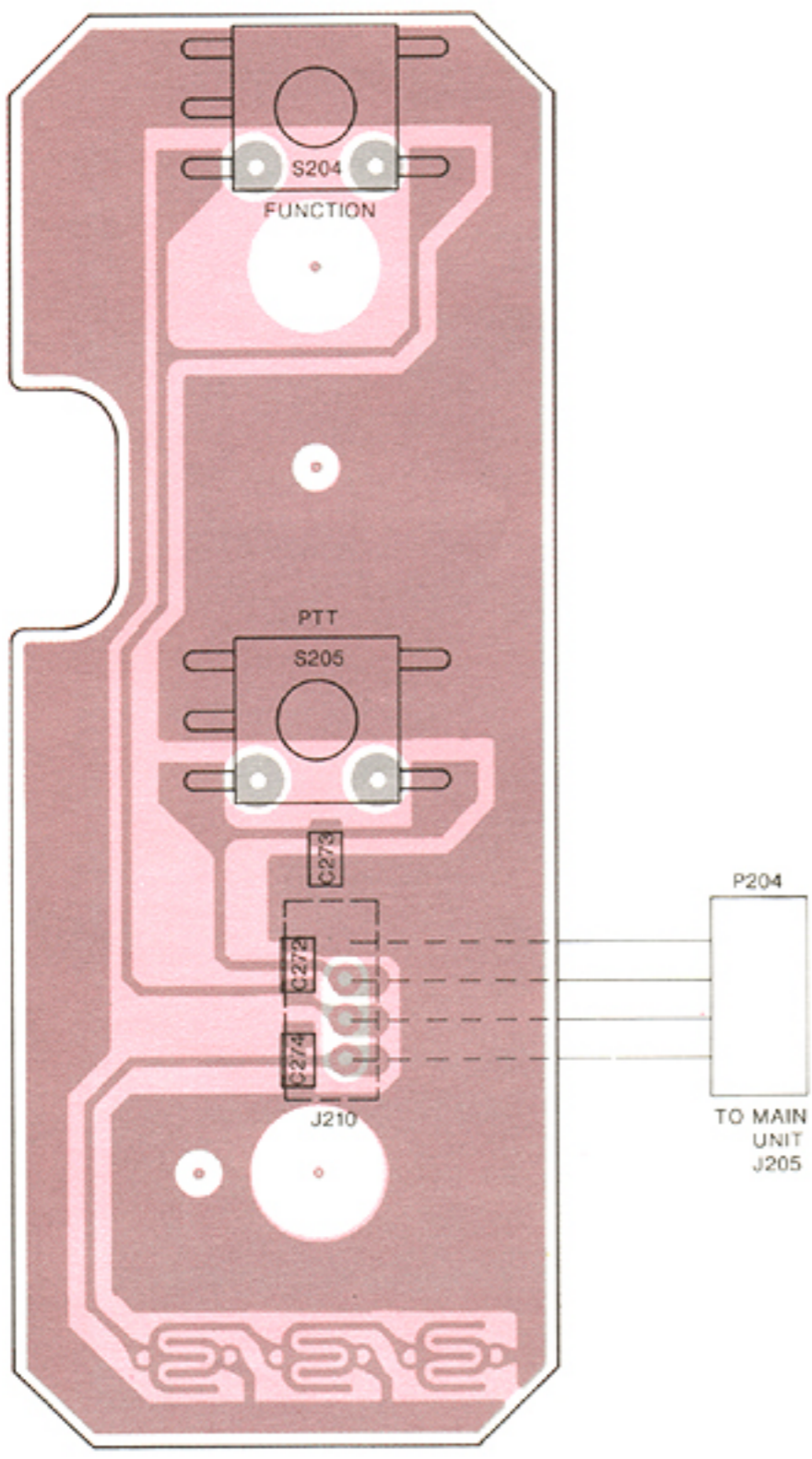

• JUNCTION UNIT

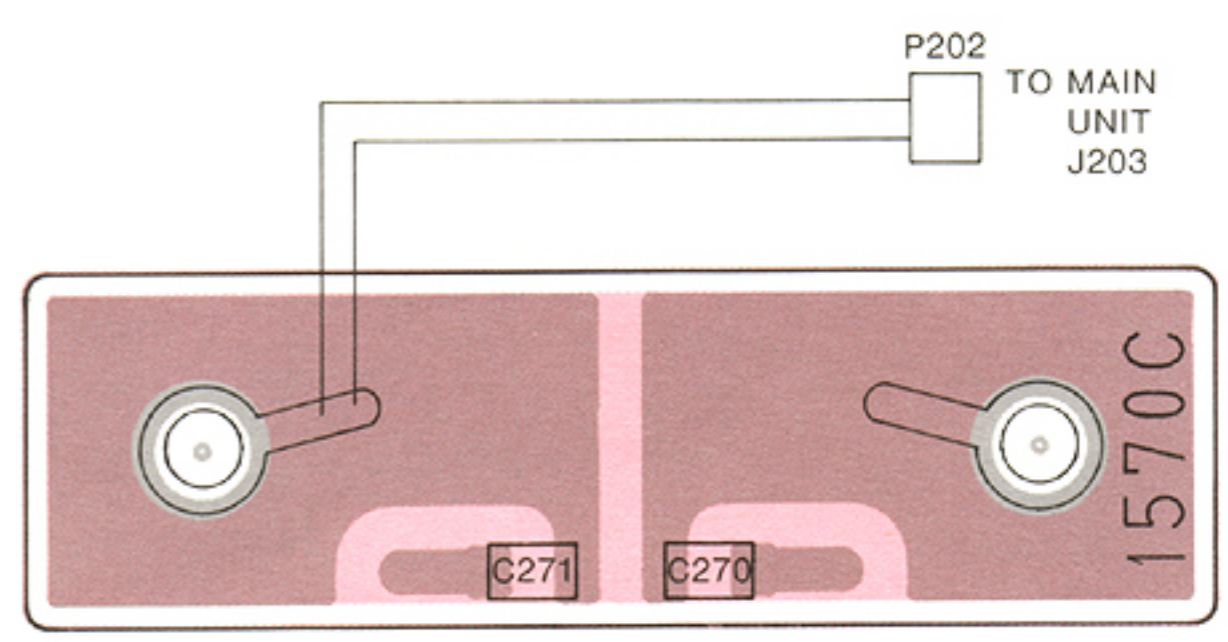

TO MAIN UNIT J203

TO MAIN UNIT J205

1570C

- TONE UNIT (IC-4GAT only)

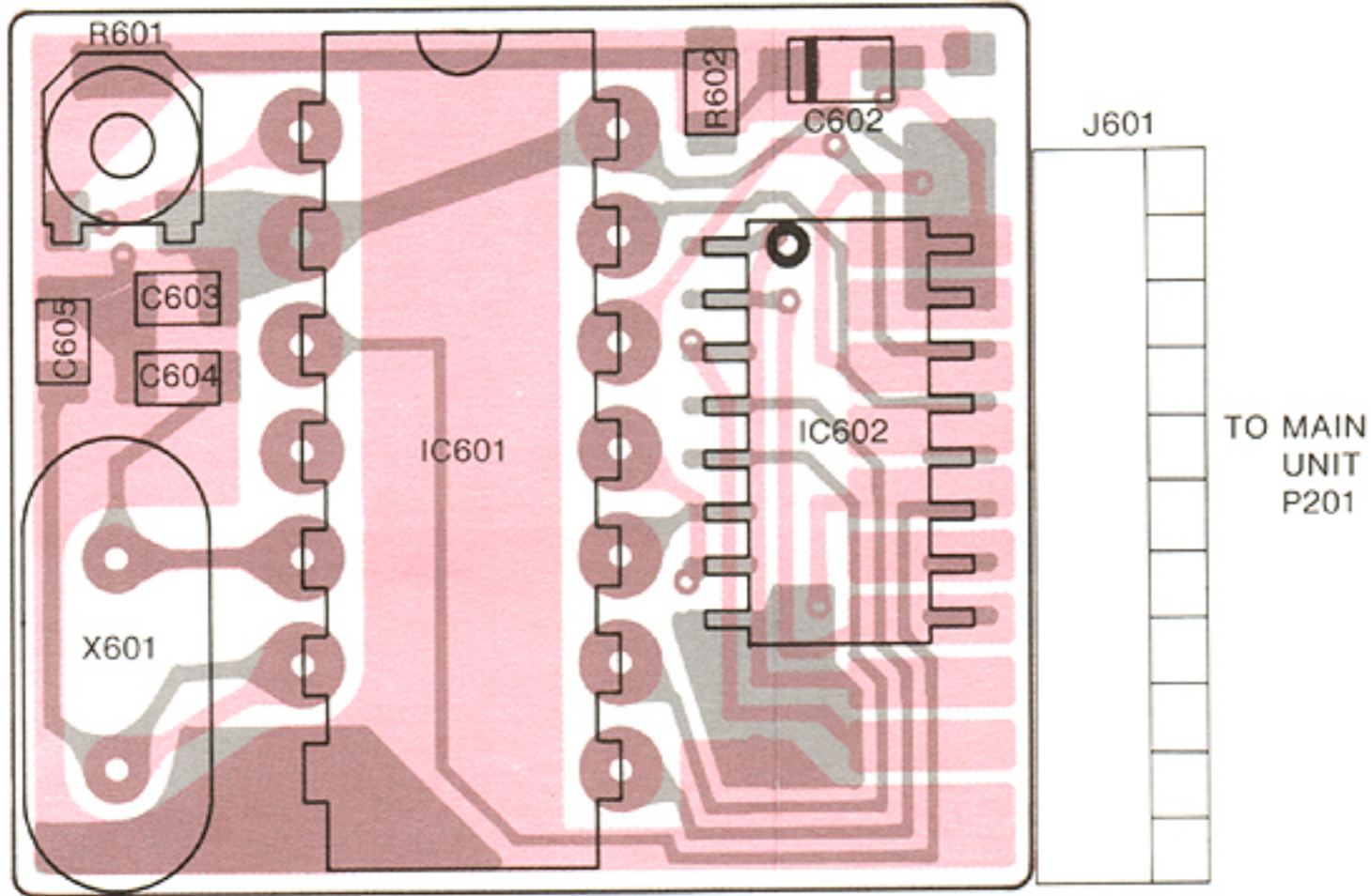

- DTMF UNIT (IC-4GAT only)

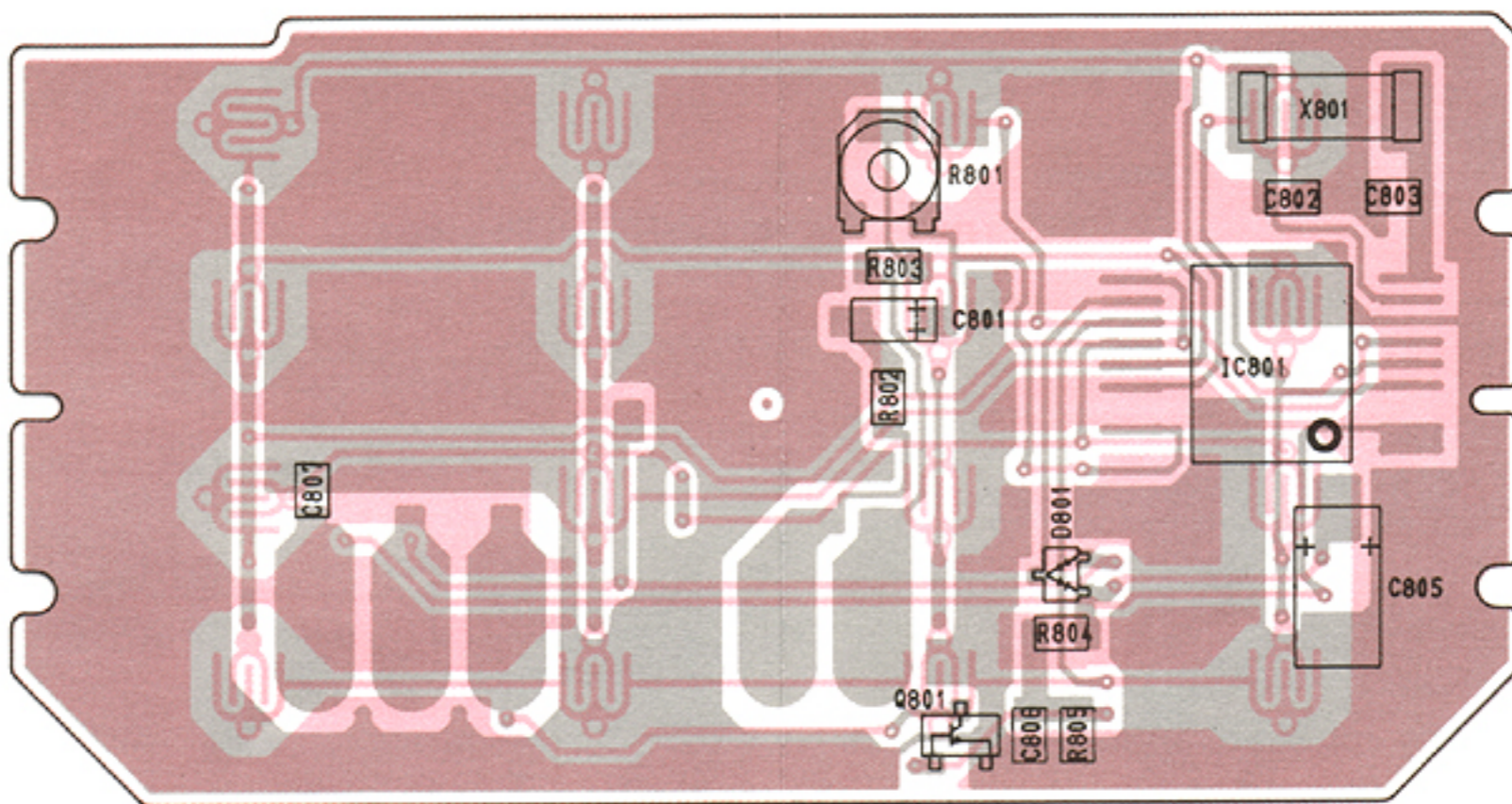

SECTION 8 VOLTAGE DIAGRAMS

8-1 LOGIC UNIT

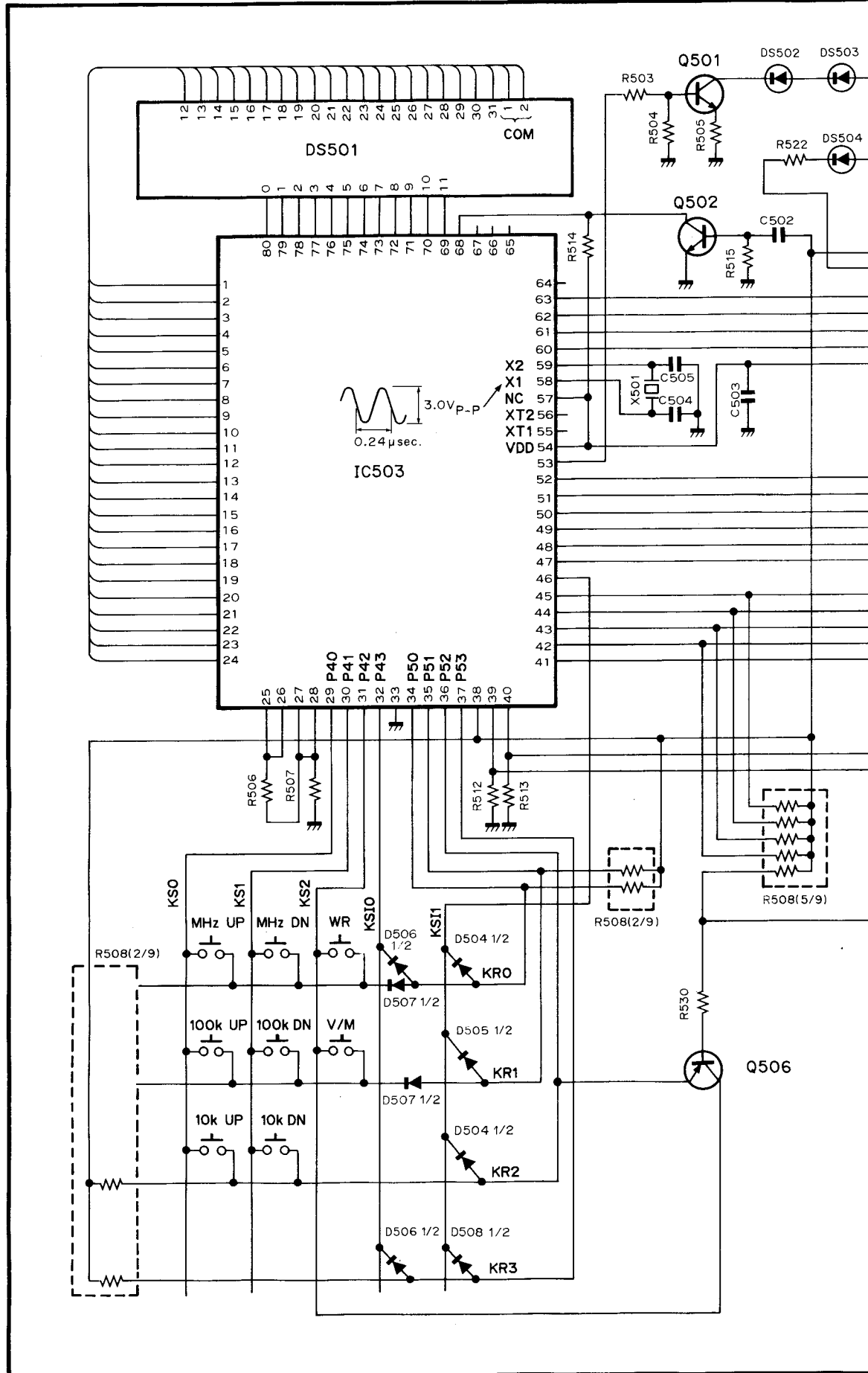

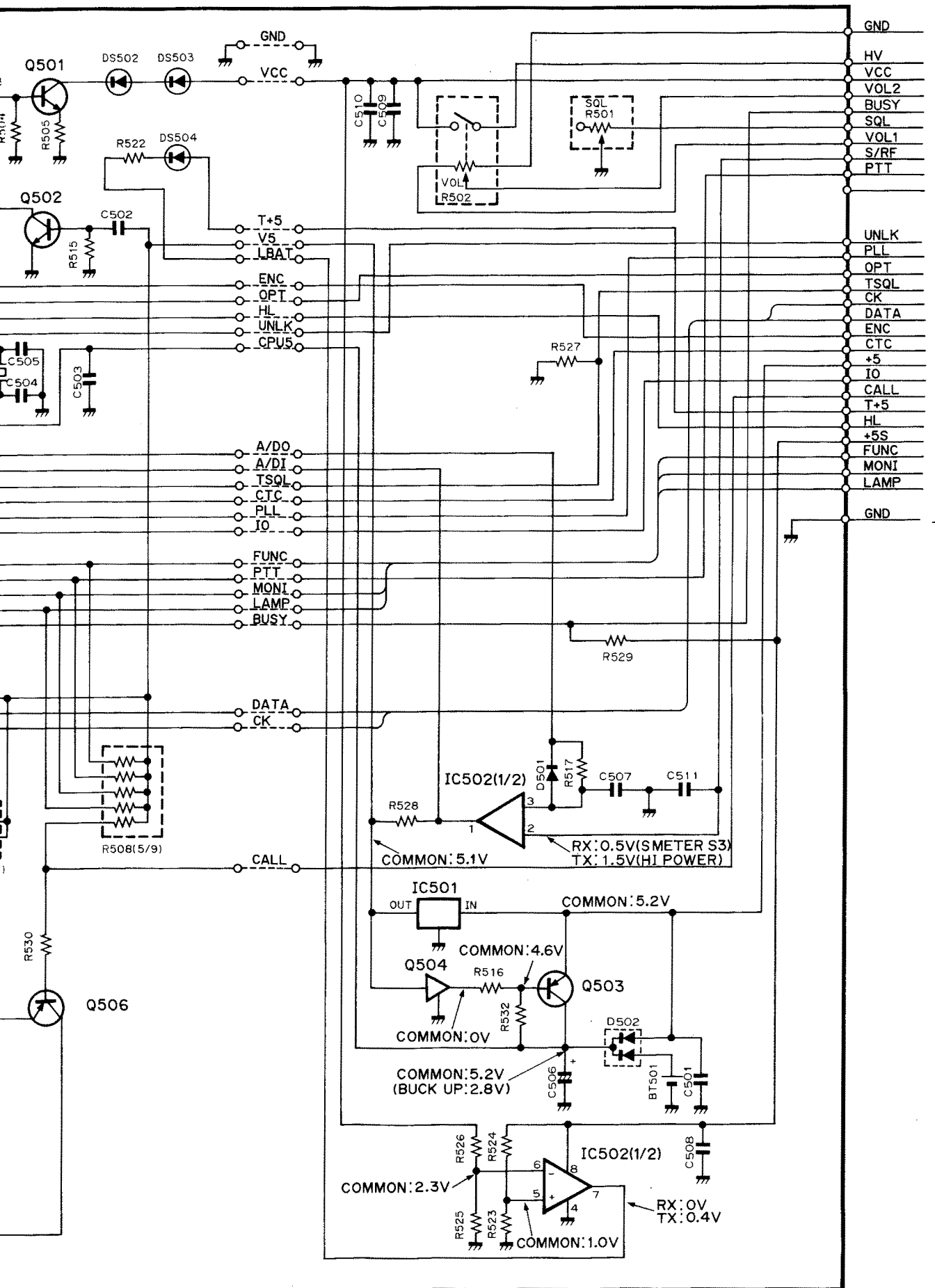

TO
MAIN
UNIT
J206

8-2 RF UNIT

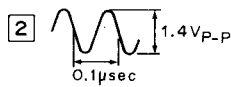
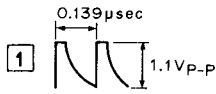
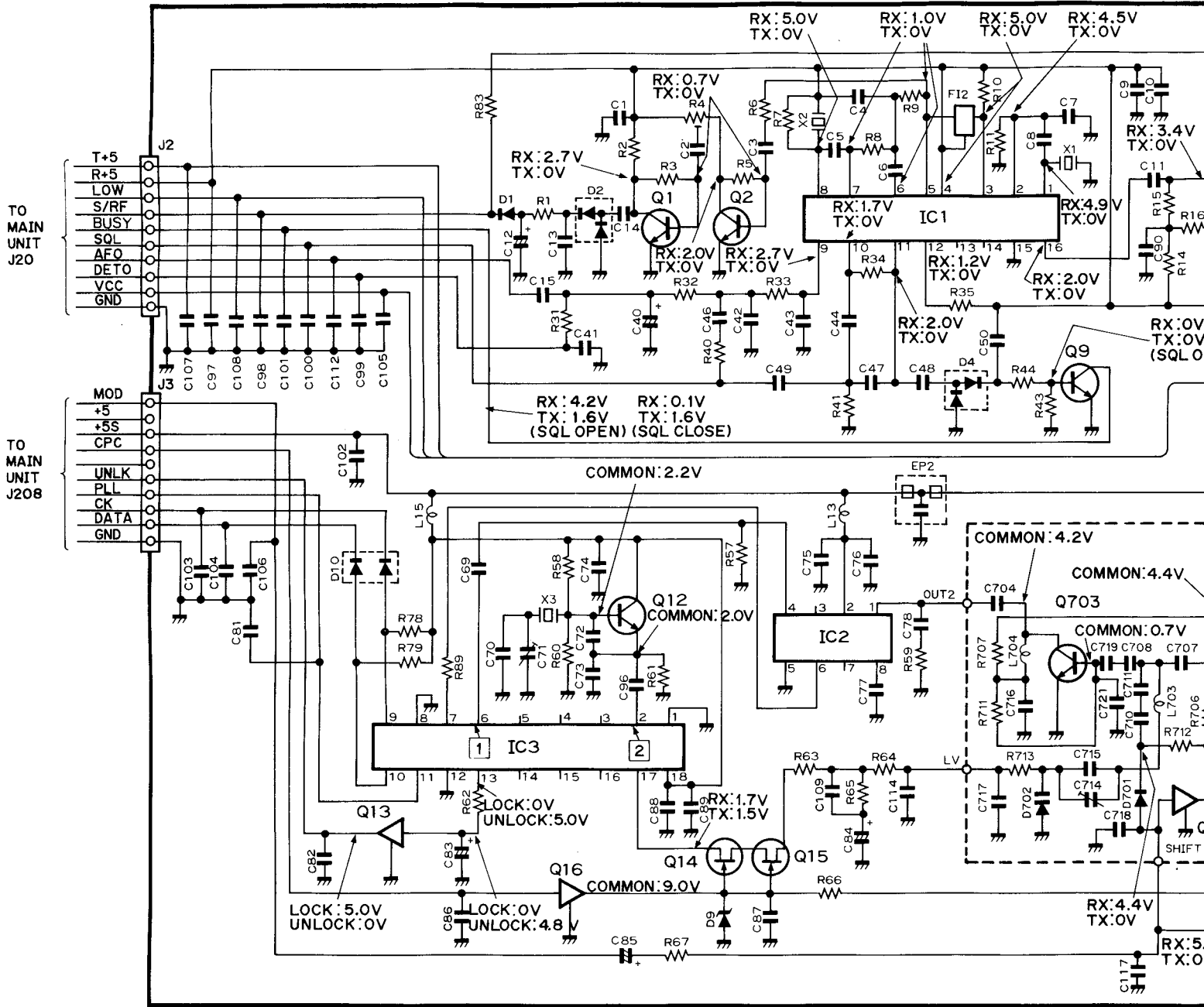

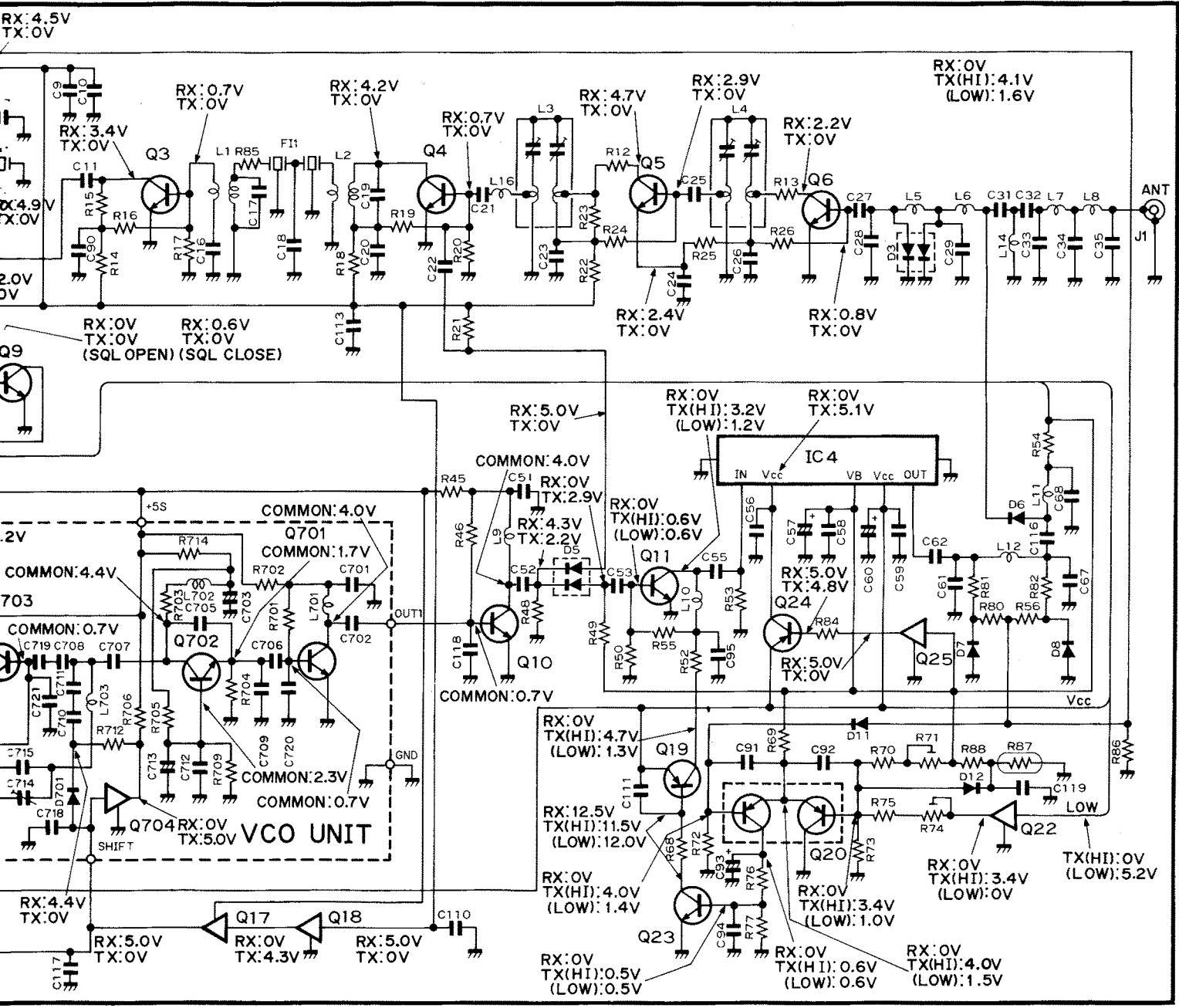

8-3 MAIN UNIT

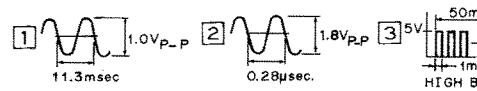
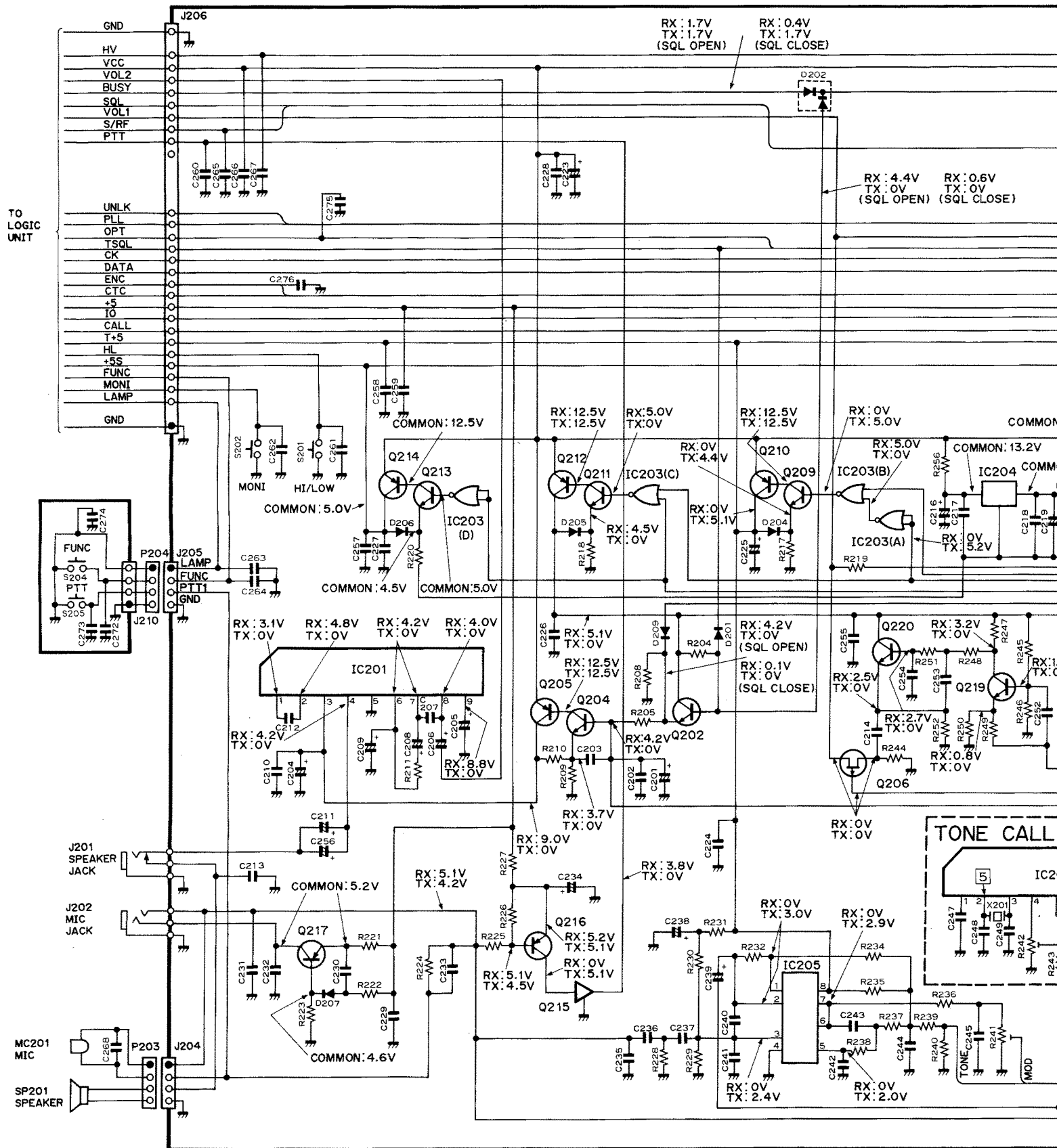

HIGH BE

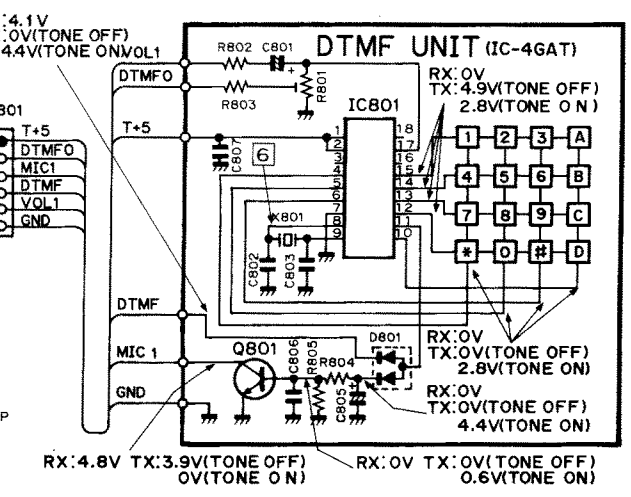
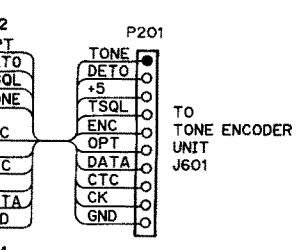
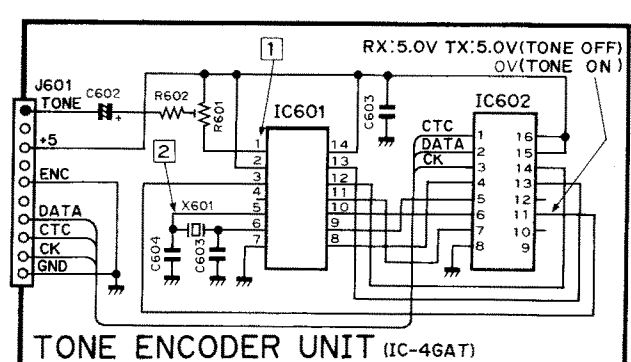
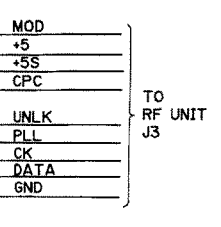
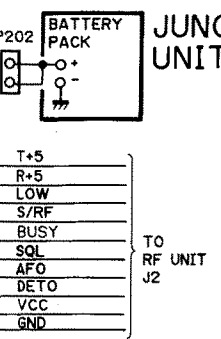
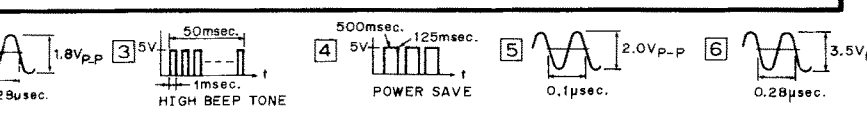
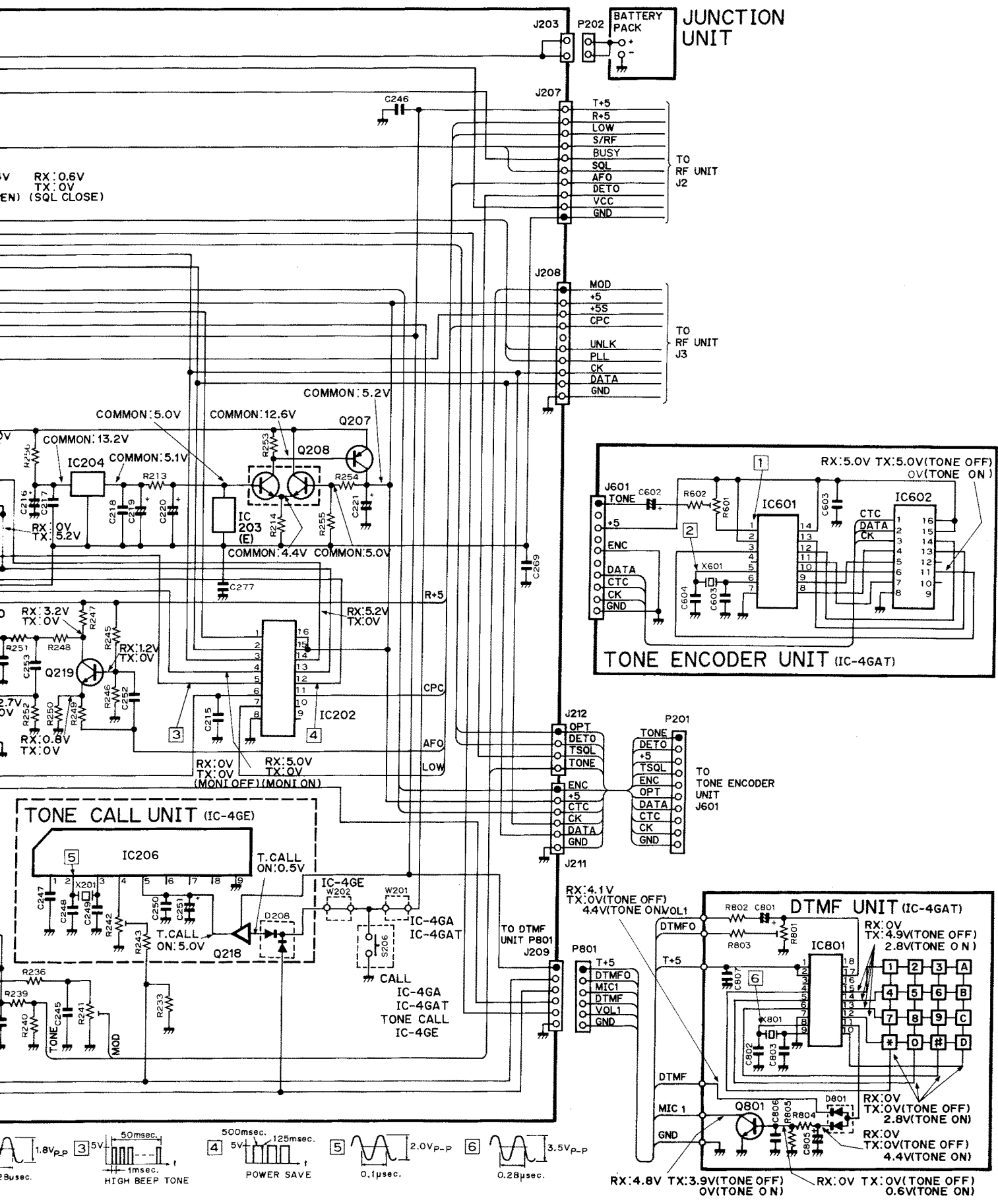

SECTION 9 PARTS LIST

MAIN UNIT

REF. NO.	DESCRIPTION	PART NO.
IC201	IC	BA526
IC202	IC	μPD4094BG
IC203	IC	LC4001BM
IC204	IC	S81250HG
IC205	IC	M5218FP
IC206	IC	TC5082P-G (IC-4GE only)
Q202	Transistor	2SC4081 R
Q204	Transistor	2SC4081 R
Q205	Transistor	2SB909M Q/R
Q206	FET	2SJ106 GR
Q207	Transistor	2SA1162 GR
Q208	Transistor	FMW1
Q209	Transistor	2SC2712 BL
Q210	Transistor	2SB909M Q/R
Q211	Transistor	2SC4081 R
Q212	Transistor	2SA1576 R
Q213	Transistor	2SC2712 BL
Q214	Transistor	2SA1162 GR
Q215	Transistor	DTC144EU
Q216	Transistor	2SA1576 R
Q217	Transistor	2SA1576 R
Q218	Transistor	RN2404 (IC-4GE only)
Q219	Transistor	2SC4081 R
Q220	Transistor	2SC4081 R
D201	Diode	DAN202U
D202	Diode	DAN202U
D204	Diode	DAP202U
D205	Diode	DAN202U
D206	Diode	DAP202U
D207	Diode	DAN202U
D208	Diode	1SS184 (IC-4GE only)
D209	Diode	DAP202U
X201	Crystal	RF4A3 FAE (7.168 MHz) (IC-4GE only)
R204	Chip resistor	47 kΩ MCR10
R205	Chip resistor	4.7 kΩ MCR10
R208	Chip resistor	22 kΩ MCR10
R209	Chip resistor	680 Ω MCR10
R210	Chip resistor	1 kΩ MCR10
R211	Chip resistor	1 kΩ MCR10
R213	Chip resistor	4.7 kΩ MCR10
R214	Chip resistor	4.7 kΩ MCR10
R217	Chip resistor	2.2 kΩ MCR10
R218	Chip resistor	10 kΩ MCR10
R219	Chip resistor	100 kΩ MCR10
R220	Chip resistor	10 kΩ MCR10
R221	Chip resistor	27 Ω MCR10
R222	Chip resistor	5.6 kΩ MCR10
R223	Chip resistor	47 kΩ MCR10
R224	Chip resistor	33 kΩ MCR10
R225	Chip resistor	2.2 kΩ MCR10
R226	Chip resistor	10 kΩ MCR10
R227	Chip resistor	470 Ω MCR10
R228	Chip resistor	47 kΩ MCR10
R229	Chip resistor	270 kΩ MCR10
R230	Chip resistor	180 kΩ MCR10
R231	Chip resistor	1 kΩ MCR10
R232	Chip resistor	180 kΩ MCR10
R233	Chip resistor	120 Ω MCR10 (except USA) 270 Ω MCR10 (USA)

MAIN UNIT

REF. NO.	DESCRIPTION	PART NO.
R234	Chip resistor	270 kΩ MCR10
R235	Chip resistor	220 kΩ MCR10
R236	Chip resistor	12 kΩ MCR10
R237	Chip resistor	82 kΩ MCR10
R238	Chip resistor	82 kΩ MCR10
R239	Chip resistor	220 kΩ MCR10
R240	Chip resistor	68 kΩ MCR10
R241	Trimmer	47 kΩ RH04A3AS4J
R242	Trimmer	10 kΩ RH04A3A14J
R243	Chip resistor	47 kΩ MCR10
R244	Chip resistor	1 MΩ MCR10
R245	Chip resistor	330 kΩ MCR10
R246	Chip resistor	150 kΩ MCR10
R247	Chip resistor	4.7 kΩ MCR10
R248	Chip resistor	39 kΩ MCR10
R249	Chip resistor	15 kΩ MCR10
R250	Chip resistor	2.2 kΩ MCR10
R251	Chip resistor	39 kΩ MCR10
R252	Chip resistor	4.7 kΩ MCR10
R253	Chip resistor	3.3 kΩ MCR10
R254	Chip resistor	560 Ω MCR10
R255	Chip resistor	22k Ω MCR10
R256	Chip resistor	470 Ω MCR10
C201	Electrolytic	2.2 μF 50 V RC3
C202	Ceramic	470 pF GRM40
C203	Ceramic	470 pF GRM40
C204	Electrolytic	47 μF 10 V RC3
C205	Electrolytic	33 μF 10 V RC3
C206	Electrolytic	0.1 μF 50 V MS5
C207	Ceramic	0.001 μF GRM40
C208	Electrolytic	1 μF 50 V RC3
C209	Electrolytic	2.2 μF 50 V RC3
C210	Ceramic	0.001 μF GRM40
C211	Electrolytic	47 μF 6.3 V MS7
C212	Ceramic	0.01 μF GRM40 F
C213	Ceramic	47 pF GRM40
C214	Ceramic	0.1 μF GRM40 F
C215	Ceramic	0.001 μF GRM40
C216	Electrolytic	33 μF 16 V RC3
C217	Ceramic	470 pF GRM40
C218	Ceramic	470 pF GRM40
C219	Electrolytic	100 μF 6.3 V MS5
C220	Electrolytic	47 μF 6.3 V MS5
C221	Electrolytic	47 μF 6.3 V MS5
C223	Electrolytic	47 μF 16 V MS5
C224	Ceramic	470 pF GRM40
C225	Electrolytic	22 μF 16 V MS5
C226	Ceramic	470 pF GRM40
C227	Ceramic	470 pF GRM40
C228	Ceramic	470 pF GRM40
C229	Ceramic	470 pF GRM40
C230	Ceramic	470 pF GRM40
C231	Ceramic	470 pF GRM40
C232	Ceramic	470 pF GRM40
C233	Ceramic	470 pF GRM40
C234	Electrolytic	1 μF 50 V MS5
C235	Ceramic	0.001 μF GRM40
C236	Ceramic	GRM40 B 103K 25PT
C237	Ceramic	0.0047 μF GRM40
C238	Electrolytic	4.7 μF 16 V MS5
C239	Tantalum	0.22 μF 35 V DN (except USA) DN (USA)
C240	Ceramic	0.1 μF 35 V GRM40
C241	Ceramic	470 pF GRM40
C242	Ceramic	120 pF GRM40
C243	Ceramic	GRM40 B 222K 50PT
C244	Ceramic	0.001 μF GRM40

MAIN UNIT

REF. NO.	DESCRIPTION	PART NO.
C245	Ceramic	GRM40 B 222K 50PT
C246	Ceramic	0.1 μF GRM40 F
C247	Ceramic	47 pF GRM40 (IC-4GE only)
C248	Ceramic	10 pF GRM40 (IC-4GE only)
C249	Ceramic	10 pF GRM40 (IC-4GE only)
C250	Ceramic	0.001 μF GRM40 (IC-4GE only)
C251	Electrolytic	0.1 μF 50 V MS5 (IC-4GE only)
C252	Ceramic	0.01 μF GRM40 F
C253	Ceramic	GRM40 B 222K 50PT
C254	Ceramic	0.001 μF GRM40
C255	Ceramic	0.1 μF GRM40 F
C256	Electrolytic	47 μF 6.3 V MS7
C257	Ceramic	470 pF GRM40
C258	Ceramic	470 pF GRM40
C259	Ceramic	470 pF GRM40
C260	Ceramic	470 pF GRM40
C261	Ceramic	470 pF GRM40
C262	Ceramic	470 pF GRM40
C263	Ceramic	470 pF GRM40
C264	Ceramic	470 pF GRM40
C265	Ceramic	470 pF GRM40
C266	Ceramic	470 pF GRM40
C267	Ceramic	470 pF GRM40
C268	Ceramic	470 pF 50 V
C269	Ceramic	470 pF GRM40
C270	Ceramic	470 pF GRM40
C271	Ceramic	470 pF GRM40
C272	Ceramic	470 pF GRM40
C273	Ceramic	470 pF GRM40
C274	Ceramic	470 pF GRM40
C275	Ceramic	470 pF GRM40
C276	Ceramic	470 pF GRM40
C277	Ceramic	470 pF GRM40
J201	Connector	HSJ0836-01-010 (speaker jack)
J202	Connector	HSJ1102-01-540 (microphone jack)
J203	Connector	PI28A02M
J204	Connector	PI28A04M
J205	Connector	PI28A04M
J206	Connector	CFP4128-0121
J207	Connector	BB04A 10F
J208	Connector	BB04A 10F
J209	Connector	PI28A06M
J210	Connector	TZB-P04H-A1
J211	Connector	TZB-P06H-A1
J212	Connector	TZB-P04H-A1
P201	Connector	PI28A10F
P202	Connector	PI28A02F
P203	Connector	PI28A04F
P204	Connector	PI28A04F
MC201	Microphone	KUC2023-01-006
S201	Switch	SKHLAD [HI/LOW]
S202	Switch	SKHLAD [MONI]
S204	Switch	SKHMPD [FUNC]
S205	Switch	SKHMPD [PTT]
S206	Switch	SKHLAD [CALL or T. CALL]
SP201	Speaker	Si36D04
W201	Jumper	MCR10-JPW
W202	Jumper	MCR10-JPW
EP201	P. C. Board	B-1562B (MAIN)
EP202	P. C. Board	B-1552C (PTT)
EP203	P. C. Board	B-1570B (JUNCTION)
EP204	IRRAX tube	d=0.7 L=2.0
EP205	Crystal seat	Order no. 8930005200 (IC-4GE only)

RF UNIT

REF. NO.	DESCRIPTION	PART NO.
IC1	IC	MC3357P
IC2	IC	MB504LP-G
IC3	IC	TC9181P
IC4	IC	SC-1081
Q1	Transistor	2SC3770 3
Q2	Transistor	2SC3770 3
Q3	Transistor	2SC3770 3
Q4	Transistor	2SC3772 3
Q5	Transistor	2SC3772 3
Q6	Transistor	2SC3772 3
Q9	Transistor	2SC2712 BL
Q10	Transistor	2SC3772 3
Q11	Transistor	2SC3772 3
Q12	Transistor	2SC2712 BL
Q13	Transistor	RN1404
Q14	FET	2SK536
Q15	FET	2SK536
Q16	Transistor	RN1404
Q17	Transistor	RN2404
Q18	Transistor	RN1404
Q19	Transistor	2SB909M Q/R
Q20	Transistor	FMS1
Q22	Transistor	RN1404
Q23	Transistor	2SC2712 BL
Q24	Transistor	2SA1298 Y
Q25	Transistor	DTC114EU
D1	Diode	1SS193
D2	Diode	HSM88AS
D3	Diode	MA862
D4	Diode	HSM88AS
D5	Diode	MA862
D6	Diode	1SS153
D7	Diode	HSM88AS
D8	Diode	HSM88AS
D9	Zener	RD9.1M B2
D10	Diode	MA159
D11	Diode	DAP202U
D12	Diode	1SS254
FI1	Monolithic	23M15B2
FI2	Ceramic	CFUM455E
X1	Crystal	CR188 (22.695 MHz)
X2	Discriminator	CDB455C7A
X3	Crystal	CR248 (10.0 MHz)
L1	Coil	LS-264
L2	Coil	LS-264
L3	Coil	5HW-F367MN-157A
L4	Coil	5HW-F367MN-157A
L5	Coil	LA-223
L6	Coil	LA-223
L7	Coil	LA-223
L8	Coil	LA-223
L9	Coil	LA-224
L10	Coil	LA-224
L11	Coil	LAL02TA R82M
L12	Coil	LA-223
L13	Coil	LAL02TA 100K
L14	Coil	LA-223
L15	Coil	LAL02TA 100K
L16	Coil	LA-222
R1	Chip resistor	100 kΩ MCR10
R2	Chip resistor	10 kΩ MCR10
R3	Chip resistor	680 kΩ MCR10
R4	Trimmer	20 kΩ EVM-LGG A00 B24

RF UNIT

REF. NO.	DESCRIPTION	PART NO.	
R5	Chip resistor	560 kΩ	MCR10
R6	Chip resistor	33 kΩ	MCR10
R7	Chip resistor	1.5 kΩ	MCR10
R8	Chip resistor	47 kΩ	MCR10
R9	Chip resistor	1.5 kΩ	MCR10
R10	Chip resistor	1.5 kΩ	MCR10
R11	Chip resistor	22 kΩ	MCR10
R12	Chip resistor	47 Ω	MCR10
R13	Chip resistor	22 Ω	MCR10
R14	Chip resistor	1 kΩ	MCR10
R15	Chip resistor	2.2 kΩ	MCR10
R16	Chip resistor	47 kΩ	MCR10
R17	Chip resistor	10 kΩ	MCR10
R18	Chip resistor	1 kΩ	MCR10
R19	Chip resistor	150 kΩ	MCR10
R20	Chip resistor	68 kΩ	MCR10
R21	Chip resistor	47 Ω	MCR10
R22	Chip resistor	100 Ω	MCR10
R23	Chip resistor	470 Ω	MCR10
R24	Chip resistor	39 kΩ	MCR10
R25	Chip resistor	47 Ω	MCR10
R26	Chip resistor	39 kΩ	MCR10
R31	Chip resistor	27 kΩ	MCR10
R32	Chip resistor	2.7 kΩ	MCR10
R33	Chip resistor	470 Ω	MCR10
R34	Chip resistor	330 kΩ	MCR10
R35	Chip resistor	100 kΩ	MCR10
R40	Chip resistor	2.2 kΩ	MCR10
R41	Chip resistor	5.6 kΩ	MCR10
R43	Chip resistor	1 MΩ	MCR10
R44	Chip resistor	100 kΩ	MCR10
R45	Chip resistor	330 Ω	MCR10
R46	Chip resistor	33 kΩ	MCR10
R48	Chip resistor	4.7 kΩ	MCR10
R49	Chip resistor	4.7 kΩ	MCR10
R50	Chip resistor	6.8 kΩ	MCR10
R52	Chip resistor	330 Ω	MCR10
R53	Chip resistor	120 Ω	MCR10
R54	Chip resistor	150 Ω	MCR10
R55	Chip resistor	22 kΩ	MCR10
R56	Chip resistor	470 Ω	MCR10
R57	Chip resistor	10 kΩ	MCR10
R58	Chip resistor	100 kΩ	MCR10
R59	Chip resistor	100 Ω	MCR10
R60	Chip resistor	100 kΩ	MCR10
R61	Chip resistor	2.2 kΩ	MCR10
R62	Chip resistor	1 kΩ	MCR10
R63	Chip resistor	1 kΩ	MCR10
R64	Chip resistor	8.2 kΩ	MCR10
R65	Chip resistor	3.3 kΩ	MCR10
R66	Chip resistor	10 kΩ	MCR10
R67	Chip resistor	100 kΩ	MCR10
R68	Chip resistor	5.6 kΩ	MCR10
R69	Chip resistor	82 kΩ	MCR10
R70	Chip resistor	2.7 kΩ	MCR10
R71	Trimmer	20 kΩ	EVM-LGG A00 B24
R72	Chip resistor	22 kΩ	MCR10
R73	Chip resistor	22 kΩ	MCR10
R74	Trimmer	5 kΩ	EVM-LGG A00 B53
R75	Chip resistor	470 kΩ	MCR10
R76	Chip resistor	220 kΩ	MCR10
R77	Chip resistor	560 kΩ	MCR10
R78	Chip resistor	47 kΩ	MCR10
R79	Chip resistor	47 kΩ	MCR10
R80	Chip resistor	470 Ω	MCR10
R81	Chip resistor	1.5 kΩ	MCR10
R82	Chip resistor	1.5 kΩ	MCR10
R83	Chip resistor	1 MΩ	MCR10
R84	Chip resistor	2.2 kΩ	MCR10

RF UNIT

REF. NO.	DESCRIPTION	PART NO.	
R85	Chip resistor	1.2 kΩ	MCR10
R86	Chip resistor	100 kΩ	MCR10
R87	Thermistor	ERT-D2FHL503S	
R88	Chip resistor	22 kΩ	MCR10
R89	Chip resistor	4.7 kΩ	MCR10
C1	Ceramic	0.1 μF	GRM40 F
C2	Ceramic	470 pF	GRM40
C3	Ceramic	15 pF	GRM40
C4	Ceramic	0.1 μF	GRM40 F
C5	Ceramic	82 pF	GRM40
C6	Ceramic	0.1 μF	GRM40 F
C7	Ceramic	39 pF	GRM40
C8	Ceramic	27 pF	GRM40
C9	Ceramic	0.1 μF	GRM40 F
C10	Ceramic	0.001 μF	GRM40
C11	Ceramic	0.001 μF	GRM40
C12	Electrolytic	0.22 μF	50 V MS7
C13	Ceramic	0.1 μF	GRM40 F
C14	Ceramic	470 pF	GRM40
C15	Ceramic	GRM40 B	103K 25PT
C16	Ceramic	0.01 μF	GRM40 F
C17	Ceramic	47 pF	GRM40
C18	Ceramic	4 pF	GRM40
C19	Ceramic	47 pF	GRM40
C20	Ceramic	470 pF	GRM40
C21	Ceramic	56 pF	GRM40
C22	Ceramic	0.5 pF	GRM40
C23	Ceramic	470 pF	GRM40
C24	Ceramic	470 pF	GRM40
C25	Ceramic	470 pF	GRM40
C26	Ceramic	470 pF	GRM40
C27	Ceramic	470 pF	GRM40
C28	Ceramic	5 pF	GRM40
C29	Ceramic	15 pF	GRM40
C31	Ceramic	4 pF	GRM40
C32	Ceramic	4 pF	GRM40
C33	Ceramic	7 pF	GRM40
C34	Ceramic	15 pF	GRM40
C35	Ceramic	7 pF	GRM40
C40	Electrolytic	0.1 μF	50 V MS7
C41	Ceramic	0.01 μF	GRM40 F
C42	Ceramic	0.001 μF	GRM40
C43	Ceramic	0.001 μF	GRM40
C44	Ceramic	0.001 μF	GRM40
C46	Ceramic	470 pF	GRM40
C47	Ceramic	33 pF	GRM40
C48	Ceramic	0.001 μF	GRM40
C49	Ceramic	470 pF	GRM40
C50	Ceramic	0.1 μF	GRM40 F
C51	Ceramic	470 pF	GRM40
C52	Ceramic	4 pF	GRM40
C53	Ceramic	47 pF	GRM40
C55	Ceramic	4 pF	GRM40
C56	Ceramic	470 pF	GRM40
C57	Electrolytic	10 μF	16 V MS7
C58	Ceramic	470 pF	GRM40
C59	Ceramic	470 pF	GRM40
C60	Electrolytic	100 μF	16 V MS7
C61	Ceramic	8 pF	GRM40
C62	Ceramic	0.001 μF	GRM40
C67	Ceramic	8 pF	GRM40
C68	Ceramic	470 pF	GRM40
C69	Ceramic	0.001 μF	GRM40
C70	Ceramic	GRM40 CH	200J 50PT
C71	Trimmer	10 pF	ECRGA010D30
C72	Ceramic	220 pF	GRM40 CH
C73	Ceramic	100 pF	GRM40 CH

RF UNIT

REF. NO.	DESCRIPTION	PART NO.
C74	Ceramic	0.001 μ F GRM40
C75	Ceramic	0.1 μ F GRM40 F
C76	Ceramic	470 pF GRM40
C77	Ceramic	0.001 μ F GRM40
C78	Ceramic	470 pF GRM40
C81	Ceramic	47 pF GRM40
C82	Ceramic	470 pF GRM40
C83	Electrolytic	10 μ F 16 V MS7
C84	Tantalum	1 μ F 35 V DN
C85	Electrolytic	1 μ F 50 V MS7
C86	Ceramic	47 pF GRM40
C87	Ceramic	470 pF GRM40
C88	Ceramic	470 pF GRM40
C89	Ceramic	0.1 μ F GRM40 F
C90	Ceramic	0.1 μ F GRM40 F
C91	Ceramic	470 pF GRM40
C92	Ceramic	470 pF GRM40
C93	Electrolytic	10 μ F 16 V MS7
C94	Ceramic	470 pF GRM40
C95	Ceramic	470 pF GRM40
C96	Ceramic	100 pF GRM40
C97	Ceramic	470 pF GRM40
C98	Ceramic	470 pF GRM40
C99	Ceramic	470 pF GRM40
C100	Ceramic	470 pF GRM40
C101	Ceramic	470 pF GRM40
C102	Ceramic	470 pF GRM40
C103	Ceramic	47 pF GRM40
C104	Ceramic	47 pF GRM40
C105	Ceramic	470 pF GRM40
C106	Ceramic	470 pF GRM40
C107	Ceramic	470 pF GRM40
C108	Ceramic	470 pF GRM40
C109	Ceramic	0.1 μ F GRM40 F
C110	Ceramic	470 pF GRM40
C111	Ceramic	470 pF GRM40
C112	Ceramic	470 pF GRM40
C113	Ceramic	0.001 μ F GRM40
C114	Ceramic	0.01 μ F GRM40 F
C115	Ceramic	470 pF GRM40
C116	Ceramic	470 pF GRM40
C117	Ceramic	470 pF GRM40
J1	Connector	BNC-R111-E (ANT)
J2	Connector	BB04G 10M (M-R)
J3	Connector	BB04G 10M (M-R)
W1	Chip jumper	MCR10-JPW
W6	Jumper	JPW-01 R-01
EP1	P. C. Board	B-1561D
EP2	Noise filter	ZJS5101-330
EP4	Filter spacer	Order no. 8930005320
EP5	IRRAX tube	d=0.7 L=6.0 (X3, C83)
EP6	IRRAX tube	d=0.7 L=5.0 (W3, W5)
EP7	IRRAX tube	d=0.7 L=7.0 (W4)
EP8	IRRAX tube	d=0.7 L=7.0 (R87)
EP9	IRRAX tube	d=0.7 L=8.0
EP10	Filament tube	W=8 L=13

VCO UNIT

REF. NO.	DESCRIPTION	PART NO.
Q701	Transistor	2SC3772 3
Q702	Transistor	2SC3356 R25
Q703	Transistor	2SC3772 3
Q704	Transistor	RN1403
D701	Diode	MA862
D702	Varicap	MA334B
L701	Coil	LQN2A 47NM
L702	Coil	LQH3N R39M
L703	Coil	LA-233
L704	Coil	LQN2A 47NM
L705	Coil	LQH3N R39M
R701	Chip resistor	33 k Ω MCR10
R702	Chip resistor	330 Ω MCR10
R703	Chip resistor	220 Ω MCR10
R704	Chip resistor	150 Ω MCR10
R705	Chip resistor	6.8 k Ω MCR10
R706	Chip resistor	47 k Ω MCR10
R707	Chip resistor	330 Ω MCR10
R709	Chip resistor	4.7 k Ω MCR10
R711	Chip resistor	47 k Ω MCR10
R712	Chip resistor	4.7 k Ω MCR10
R713	Chip resistor	1 k Ω MCR10
R714	Chip resistor	100 Ω MCR10
C701	Ceramic	470 pF GRM40
C702	Ceramic	4 pF GRM40
C703	Ceramic	1 μ F 16 V SV
C704	Ceramic	4 pF GRM40
C705	Ceramic	7 pF GRM40
C706	Ceramic	0.5 pF GRM40
C707	Ceramic	8 pF GRM40
C708	Ceramic	0.5 pF GRM40
C709	Ceramic	8 pF GRM40
C710	Ceramic	6 pF GRM40
C711	Ceramic	5 pF GRM40
C712	Ceramic	470 pF GRM40
C713	Ceramic	1 μ F 16 V SV
C714	Trimmer	ECR-LB010A12
C715	Ceramic	12 pF GRM40
C716	Ceramic	470 pF GRM40
C717	Ceramic	470 pF GRM40
C718	Ceramic	470 pF GRM40
C719	Ceramic	0.5 pF GRM40
C720	Ceramic	10 pF GRM40
C721	Ceramic	10 pF GRM40
EP701	P. C. Board	B-1563C

LOGIC UNIT

REF. NO.	DESCRIPTION	PART NO.	
IC501	IC	S-8054ALB-LM	
IC502	IC	LA6393M	
IC503	IC	μPD75308GF-034-3B9	
Q501	Transistor	2SC4081 R	
Q502	Transistor	2SC4081 R	
Q503	Transistor	2SA1362 GR	
Q504	Transistor	RN1404	
Q506	Transistor	2SA1576 R	
D501	Diode	1SS193	
D502	Diode	1SS184	
D504	Diode	1SS196 (IC-4GE only) 1SS193 (IC-4GAT USA only)	
D505	Diode	1SS193	
D506	Diode	1SS184	
D507	Diode	MA159	
X501	Crystal	CR227	
R501	Variable resistor	10 kΩB	RK0791110
R502	Variable resistor	10 kΩA	RK0971111
R503	Chip resistor	4.7 kΩ	MCR10
R504	Chip resistor	2.2 kΩ	MCR10
R505	Chip resistor	47Ω	MCR10
R506	Chip resistor	47 kΩ	MCR10
R507	Chip resistor	47 kΩ	MCR10
R508	Array	MA5025 F	09 224 J
R512	Chip resistor	1 MΩ	MCR10
R513	Chip resistor	1 MΩ	MCR10
R514	Chip resistor	100 kΩ	MCR10
R515	Chip resistor	100 kΩ	MCR10
R516	Chip resistor	47 kΩ	MCR10
R517	Chip resistor	1.2 MΩ	MCR10
R522	Chip resistor	220 Ω	MCR10
R523	Chip resistor	100 kΩ	MCR10
R524	Chip resistor	330 kΩ	MCR10
R525	Chip resistor	100 kΩ	MCR10
R526	Chip resistor	390 kΩ	MCR10
R527	Chip resistor	1 MΩ	MCR10
R528	Chip resistor	220 kΩ	MCR10
R529	Chip resistor	1 MΩ	MCR10
R530	Chip resistor	1 MΩ	MCR10
R532	Chip resistor	1 MΩ	MCR10
C501	Ceramic	0.1 μF	GRM40 F
C502	Ceramic	0.01 μF	GRM40 F
C503	Ceramic	0.001 μF	GRM40
C504	Ceramic	15 pF	GRM40
C505	Ceramic	15 pF	GRM40
C506	Tantalum	47 μF	6.3 V SV
C507	Ceramic	330 pF	GRM40 CH
C508	Ceramic	0.001 μF	GRM40
C509	Ceramic	0.1 μF	GRM40 F
C510	Ceramic	0.001 μF	GRM40
C511	Ceramic	470 pF	GRM40
DS501	LCD	E-9248-2	
DS502	LED	SLM-13MW	
DS503	LED	SLM-13MW	
DS504	LED	SLM-13VW	
BT501	Lithium battery	BR2325-1HC	
EP501	P. C. Board	B-1564C (LOGIC-A)	
EP502	P. C. Board	B-1565B (LOGIC-B)	

LOGIC UNIT

REF. NO.	DESCRIPTION	PART NO.	
EP503	P. C. Board	B-1555A (SQL)	
EP504	P. C. Board	B-1556B (OFF/VOL)	
EP505	Flexible P. C. Board	B-1568A (MAIN ~ LOGIC)	
EP506	Flexible P. C. Board	B-1569A (LOGIC-A ~ B)	
EP507	LCD contact strip	SRCN573	

TONE UNIT (IC-4GAT only)

REF. NO.	DESCRIPTION	PART NO.	
IC601	IC	S7116A	
IC602	IC	μPD4094BG	
X601	Crystal	RF4A3 FAA 3.579545 MHz	
R601	Trimmer	47 kΩ	RH04A3AS4J
R602	Chip resistor	47 kΩ	MCR10
C602	Tantalum	0.47 μF	25 V SV
C603	Ceramic	470 pF	GRM40
C604	Ceramic	47 pF	GRM40
C605	Ceramic	39 pF	GRM40
J601	Connector	PI28A10M	
EP601	P. C. Board	B-1566B	
EP602	Crystal seat	Order no. 8930005200	
EP603	Sponge	Order no. 43873 (BC)	

DTMF UNIT (IC-4GAT only)

REF. NO.	DESCRIPTION	PART NO.	
IC801	IC	LR40872	
Q801	Transistor	2SC2712 BL	
D801	Diode	DAP202U	
X801	Ceramic resonator	CSAC3.58MGC300CD	
R801	Trimmer	10 kΩ	RH04A3A14J
R802	Chip resistor	33 kΩ	MCR10
R803	Chip resistor	22 kΩ	MCR10
R804	Chip resistor	47 kΩ	MCR10
R805	Chip resistor	68 kΩ	MCR10
C801	Tantalum	0.47 μF	25 V SV
C802	Ceramic	GRM40 SL	300J 50PT
C803	Ceramic	GRM40 SL	300J 50PT
C804	Tantalum	2.2 μF	10 V SV
C805	Tantalum	TESVC1A106M12L	
C806	Ceramic	470 pF	GRM40
C807	Ceramic	470 pF	GRM40
P801	Connector	PI28A06F	
EP801	P. C. Board	B-1567B	

LOGIC UNIT

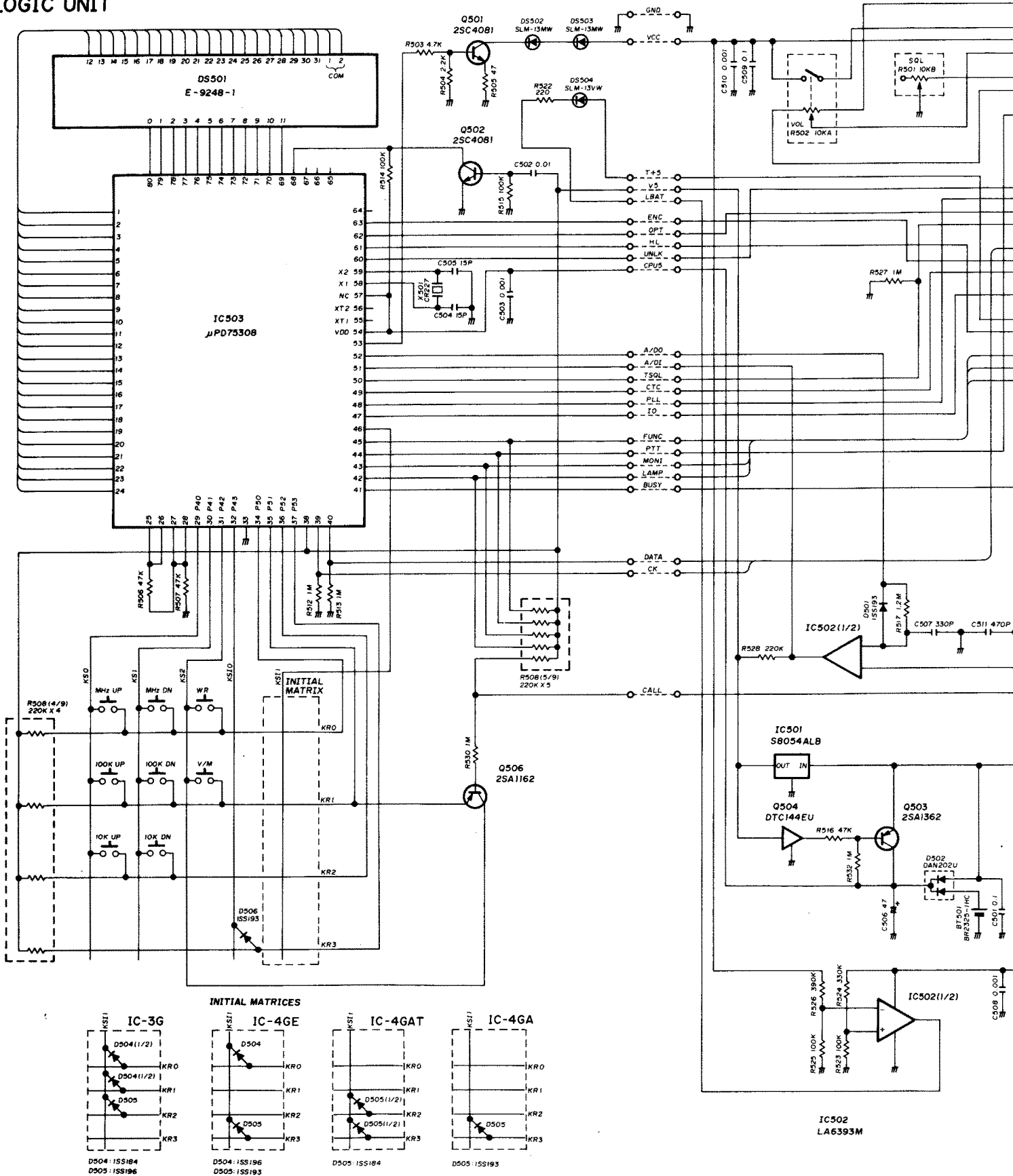

GE IC-4GA

SCHEMATIC DIAGRAM

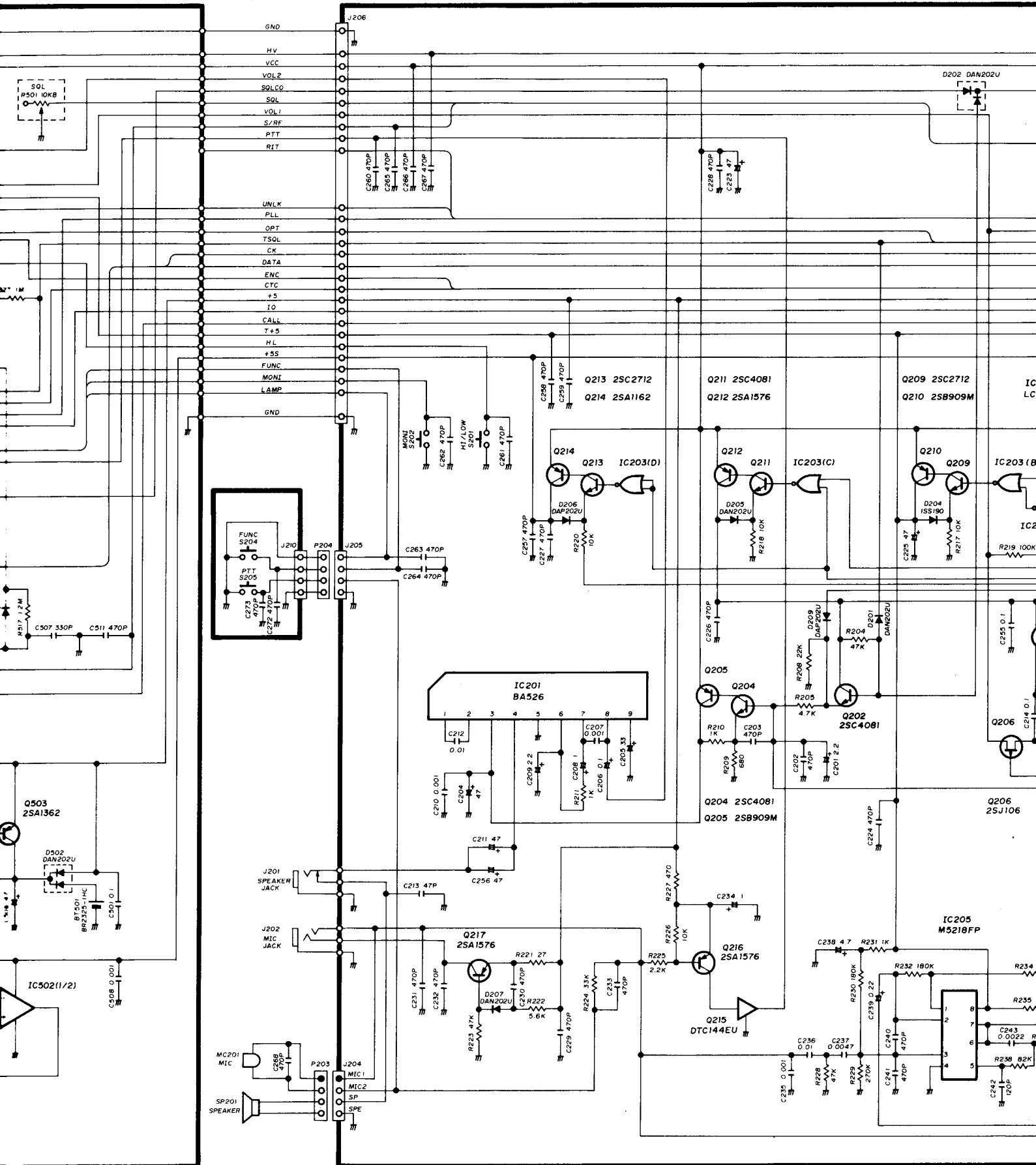

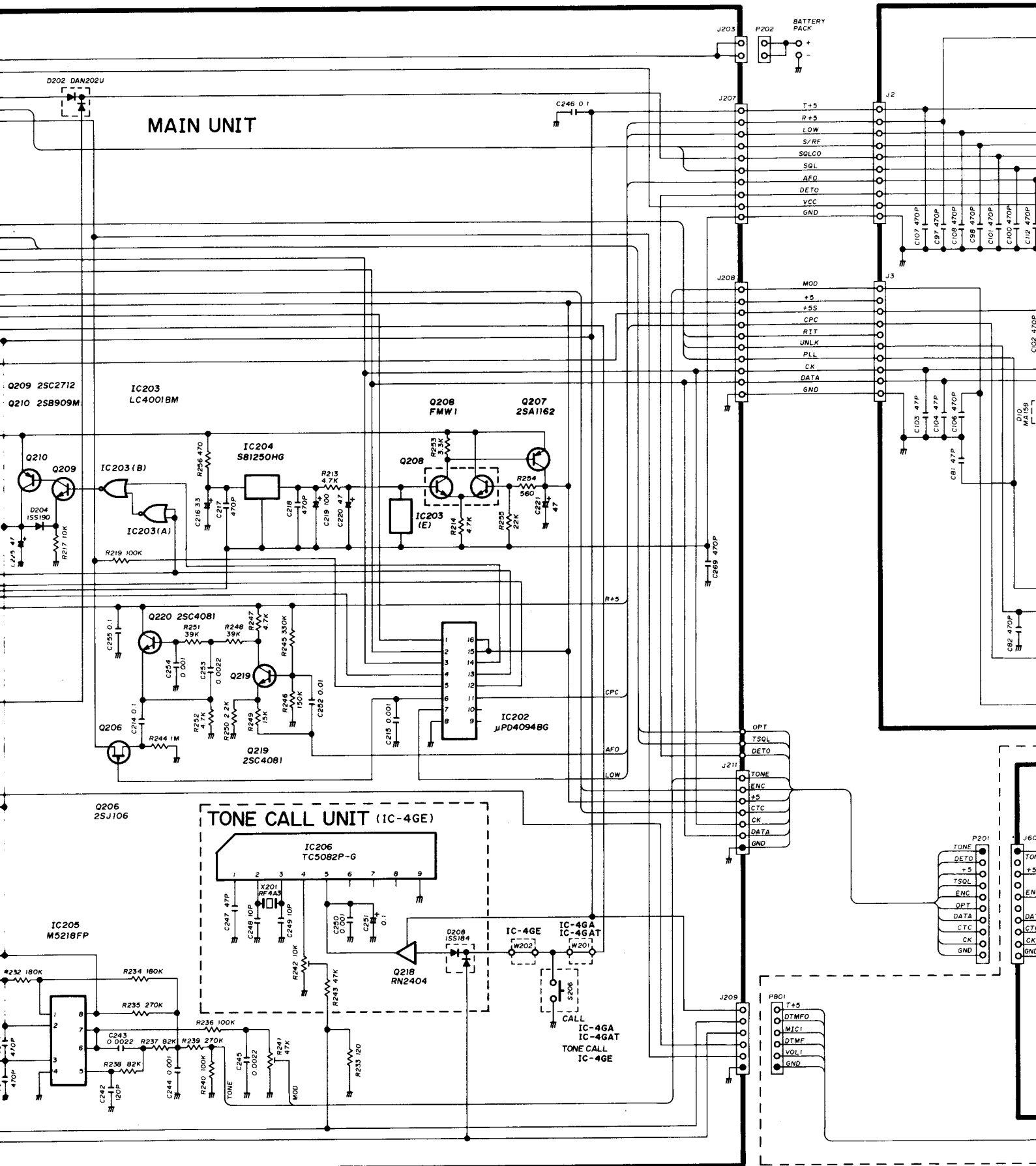

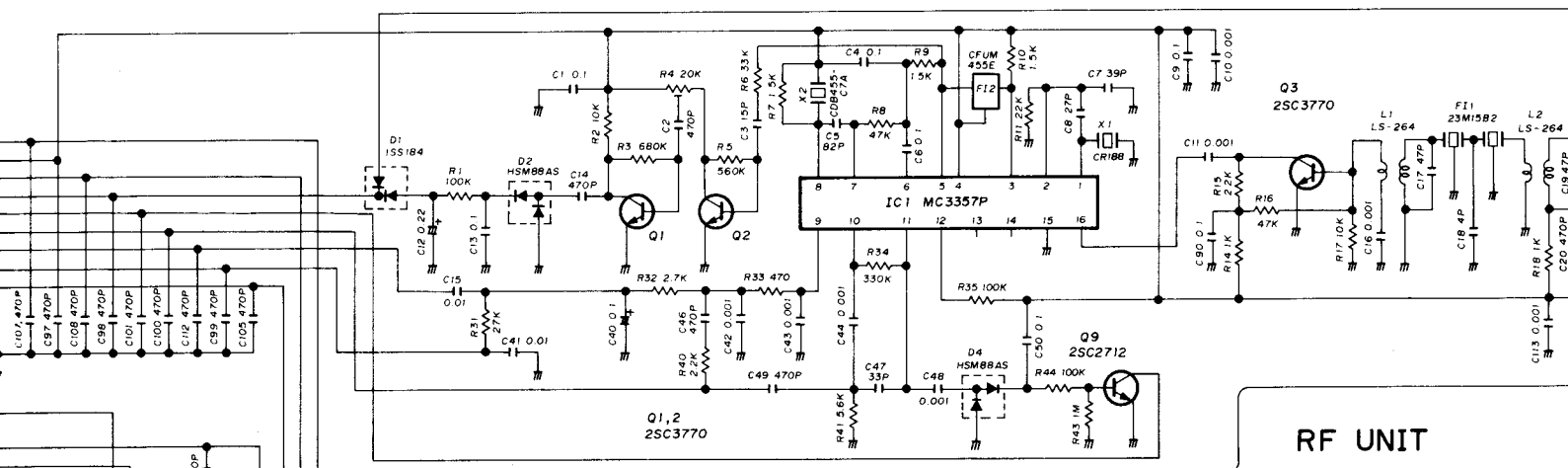

RF UNIT

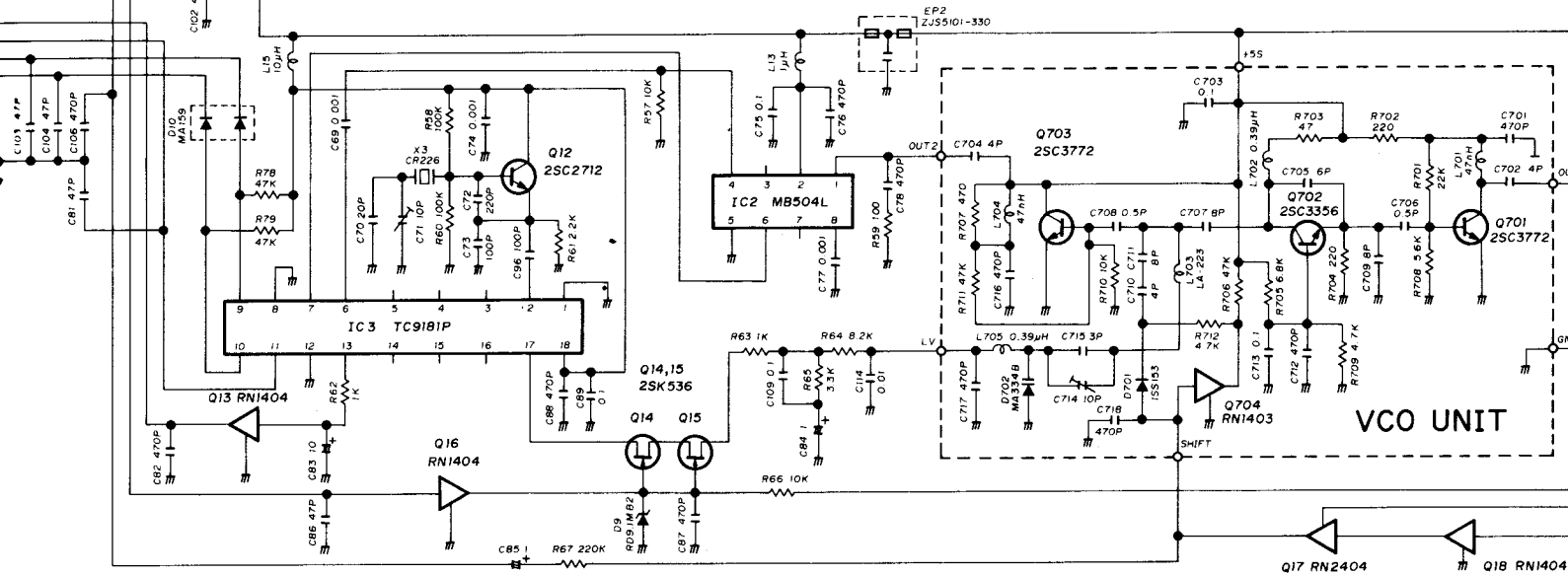

VCO UNIT

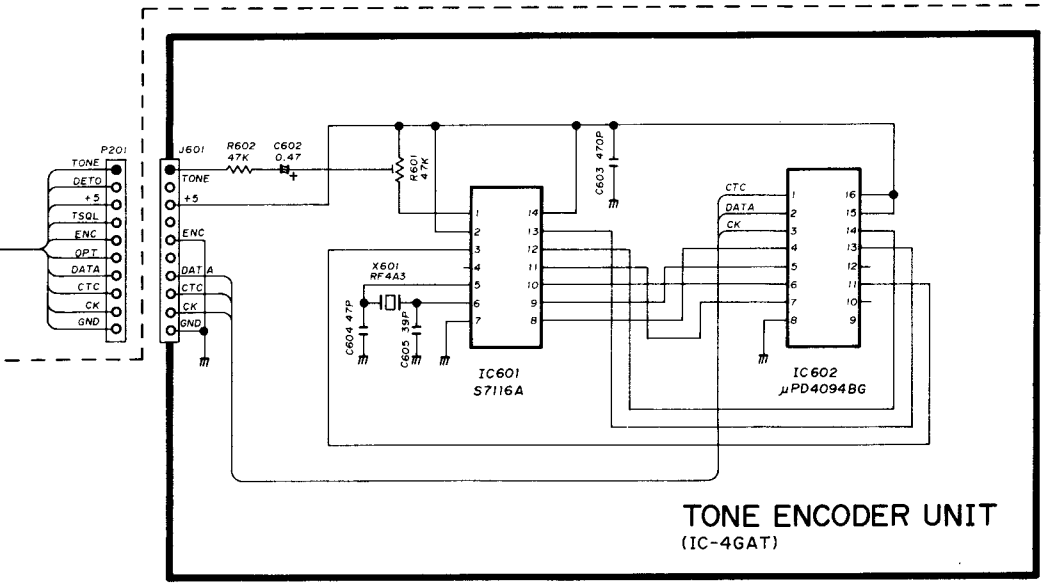

**TONE ENCODER UNIT
(IC-4GAT)**

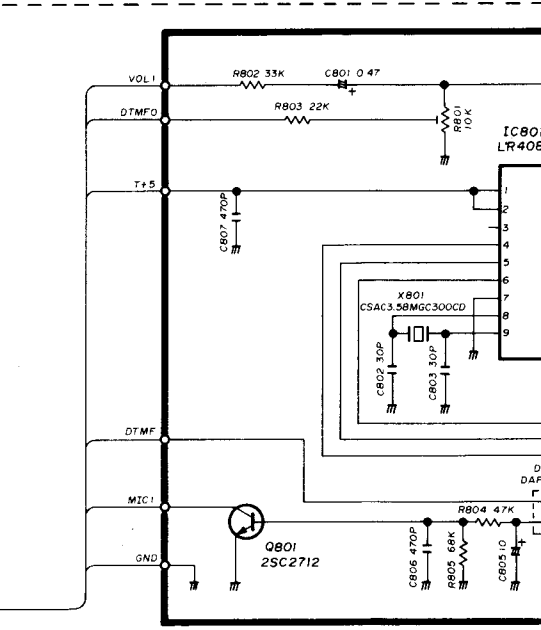

**IC801
LR400**

**IC802
μPD4094BG**

**IC801
LR400**

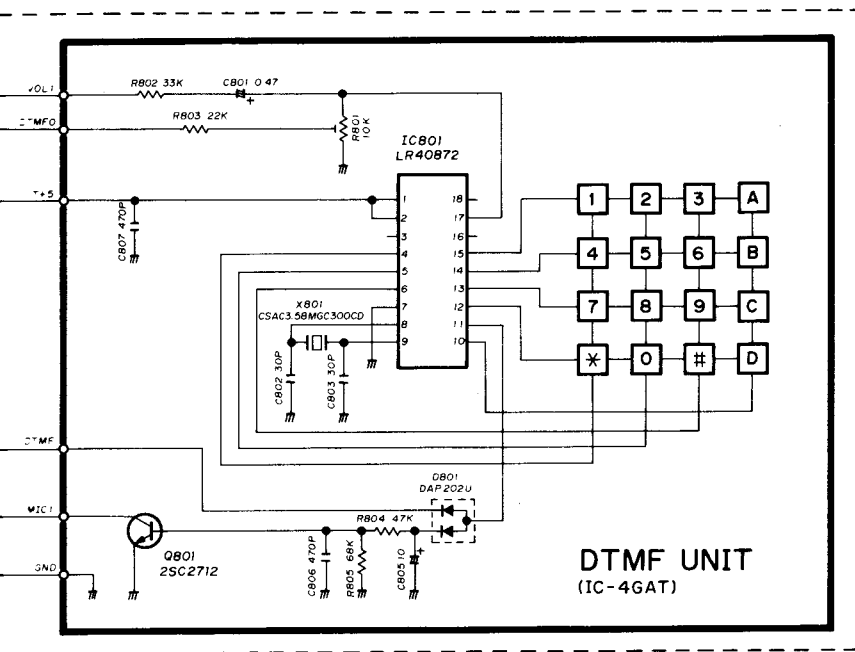
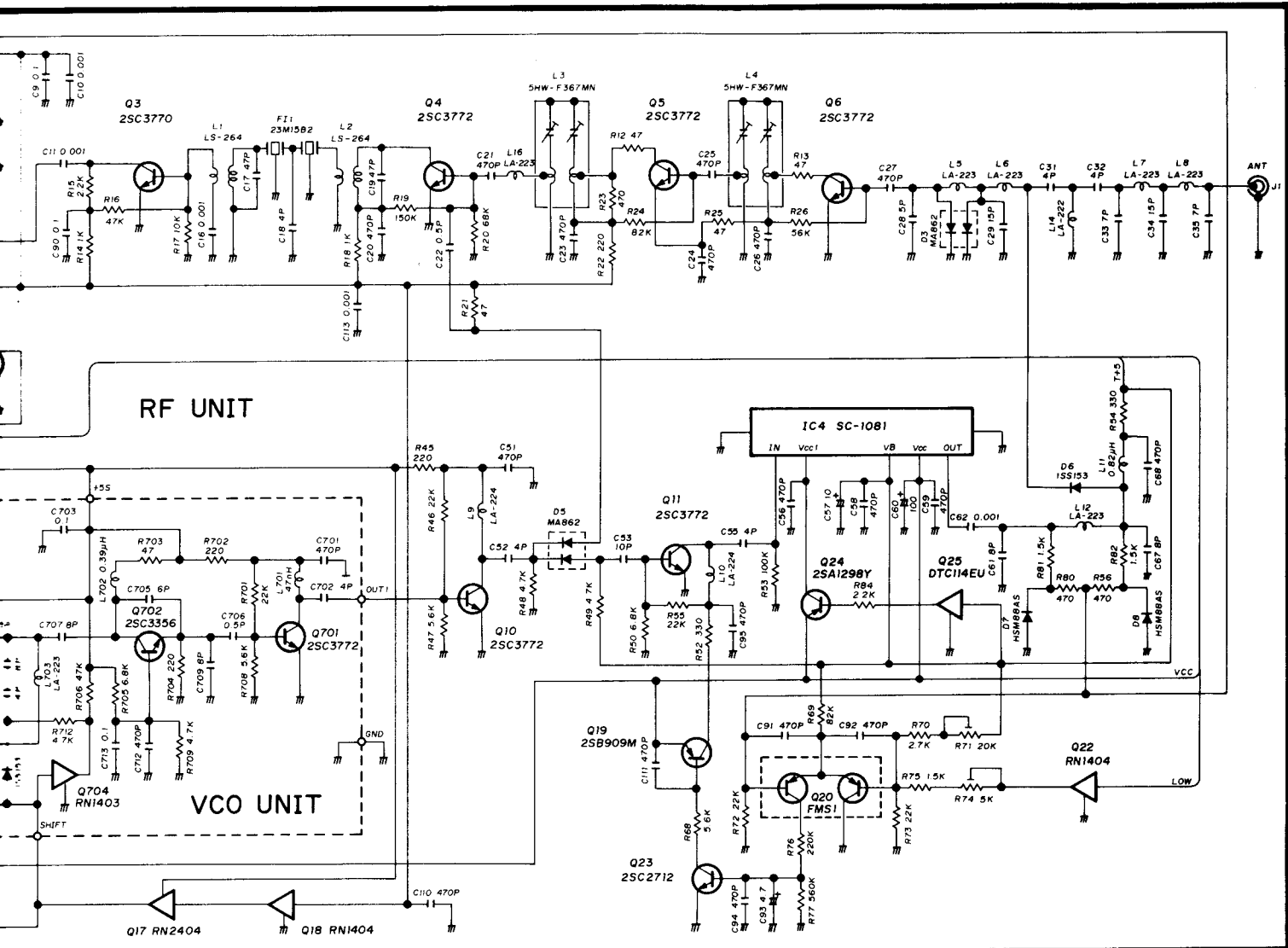

To upgrade quality, some components may be subject to change without notice.

Icom Inc.

6-9-16, Kamihigashi,
Hirano-ku, Osaka 547, Japan
Phone: (06) 793-5301
Fax : (06) 793-0013
Telex : 05277822 ICOMTR J

ICOM AMERICA INC.

<Corporate Headquarters>
2380 116th Avenue N.E., Bellevue, WA
98004, U.S.A.
Phone: (206) 454-8155
Fax : (206) 454-1509
Telex : 152210 ICOM AMER BVUE

<Customer Service>
Phone: (206) 454-7619

<Regional Customer Service Centers>
3150 Premier Drive, Suite 126, Irving, TX
75063, U.S.A.
Phone: (214) 550-7525
Fax : (214) 550-7423

1777 Phoenix Parkway, Suite 201, Atlanta,
GA 30349, U.S.A.
Phone: (404) 991-6166
Fax : (404) 991-6327

ICOM CANADA

A Division of Icom America Inc.
3071 #5 Road, Unit 9, Richmond, B.C.,
V6X 2T4, Canada
Phone: (604) 273-7400
Fax : (604) 273-1900

ICOM (EUROPE) GMBH

Communication Equipment
Himmelgeister Str. 100, 4000 Düsseldorf 1,
W. Germany
Phone: 0211-346047
Fax : 0211-333639
Telex : 8588082 ICOM D

ICOM (AUSTRALIA) PTY. LTD.

Incorporated In Victoria
7 Duke Street, Windsor, Victoria, 3181,
Australia
Phone: (03) 529-7582.
Fax : (03) 529-8485
Telex : AA 35521 ICOM AS

ICOM (UK) LTD.

Unit 9, Sea St., Herne Bay, Kent, U.K.
Phone: 0227-363859
Fax : 0227-360155
Telex : 965179 ICOM G

ICOM FRANCE S.A.

120 Route de Revel, BP4063, 31029
Toulouse Cedex, France
Phone: 61.20.31.49
Fax : 61.34.05.91
Telex : 521515 ICOM FRA

Count on us!

